

ES933ML/MIC & ES933WML/MIC

MicroLine® Condenser Hanging Microphones



Engineered Sound® Microphones

Features

- MicroLine® polar pattern provides narrow 90° acceptance angle
- Low-profile design with low-reflectance finish for minimum visibility
- Superior off-axis rejection for maximum gain before feedback
- UniGuard® RFI-shielding technology offers outstanding rejection of radio frequency interference (RFI)
- Available interchangeable elements permit angle of acceptance from 90° to 360°
- Steel hanger positions microphone over choirs, instrumental groups and theater stages
- Available in two colors: black (ES933ML/MIC) and white (ES933WML/MIC)

Description

The ES933ML/MIC is a wide-range miniature condenser microphone with a MicroLine® (line cardioid) polar pattern. It is designed for quality sound reinforcement, professional recording, television and other demanding sound pickup applications. The combination of small size and excellent response makes the microphone ideal for suspension over choirs, instrumental groups or theater stages.

The microphone requires a compatible Audio-Technica power module (not included) for operation.

The microphone is equipped with UniGuard® RFI-shielding technology, which offers outstanding rejection of radio frequency interference (RFI).

The microphone's MicroLine® (line cardioid) polar pattern provides a 90° angle of acceptance. Additional interchangeable elements with omnidirectional (360°), cardioid (120°) and hypercardioid (100°) pickup patterns are available.

The microphone include a 15.2 m (50') permanently attached miniature cable. Its free end connects to a compatible Audio-Technica power module (not included) via a special TA3F-type connector designed to optimize RFI immunity.

The microphone comes equipped with a vinyl-coated steel hanger for positioning over a choir/orchestra/stage, and a two-stage foam windscreens. The microphone is enclosed in a rugged housing with a low-reflectance black finish. It is also available with white housing, cable, hanger and windscreens as the ES933WML/MIC.

Installation and Operation

The ES933ML/MIC requires a compatible Audio-Technica power module (not included) for operation.

A uniform 90° angle of acceptance provides well-balanced audio pickup. The microphone should be located forward of the front-most source, above the rear-most source, and "aimed" between them (Fig. 1). Increasing the height of the mic above the sources will tend to equalize sound levels between them, but may also increase background/ reverberant sound pickup. When possible, the distance from the mic to the rear-most source should be no more than twice the distance to the front source, to maintain front-to-rear balance (Fig. 1).

Width of pickup is approximately 1.5 times the distance to the closest source. If additional mics are needed for wide sources, they should be positioned apart laterally at least 1.5 times the distance to the front source, to avoid phase cancellation (Fig. 2).

To orient the microphone in the proper direction, twist the housing slightly in its wire holder. (Clockwise rotation moves the microphone to the right; counterclockwise rotation moves it to the left.)

The provided two-stage foam windscreens simply snaps over the head of the microphone, effectively reducing noise from wind or ventilation air currents.

Avoid leaving the microphone in the open sun or in areas where temperatures exceed 110° F (43° C) for extended periods. Extremely high humidity should also be avoided.

Note: Audio-Technica has developed a special RFI-shielding mechanism, which is an integral part of the connectors in the Engineered Sound® line. If you remove or replace the connector, you may adversely affect the unit's RFI immunity. Audio-Technica offers a crimp tool (ATCT) and RFI shields that enable you to shorten the cable and correctly reinstall the connector while maintaining the highest level of RFI immunity.

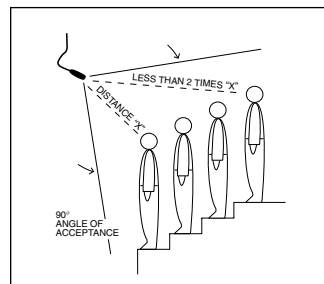

Figure 1

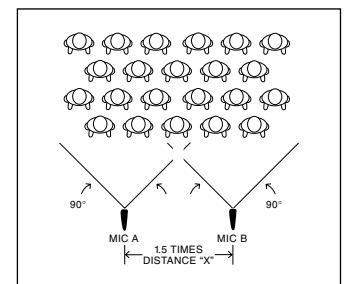

Figure 2

ES933ML/MIC & ES933WML/MIC

To reduce the environmental impact of a multi-language printed document, product information is available online at www.audio-technica.com in a selection of languages.

Afin de réduire l'impact sur l'environnement de l'impression de plusieurs langues, les informations concernant les produits sont disponibles sur le site www.audio-technica.com dans une large sélection de langues.

Para reducir el impacto al medioambiente, y reducir la producción de documentos en varios lenguajes, información de nuestros productos están disponibles en nuestra página del Internet: www.audio-technica.com.

Para reduzir o impacto ecológico de um documento impresso de várias línguas, a Audio-Technica providência as informações dos seus produtos em diversas línguas na www.audio-technica.com.

Per evitare l'impatto ambientale che la stampa di questo documento determinerebbe, le informazioni sui prodotti sono disponibili online in diverse lingue sul sito www.audio-technica.com.

Der Umwelt zuliebe finden Sie die Produktinformationen in deutscher Sprache und weiteren Sprachen auf unserer Homepage: www.audio-technica.com.

Om de gevolgen van een gedrukte meertalige handleiding op het milieu te verkleinen, is productinformatie in verschillende talen "on-line" beschikbaar op: www.audio-technica.com.

本公司基於減少對環境的影響，將不作多語言文件的印刷，有關產品訊息可在 www.audio-technica.com 的官方網頁上選擇所屬語言及瀏覽。

本公司基于减少对环境的影响，将不作多语言文档的印刷，有关产品信息可在 www.audio-technica.com 的官方网页上选择所属语言和浏览。

자원절약, 환경보호를 위해 국문 사용 설명서는 인쇄하지 않았습니다. 제품정보는 www.audio-technica.com 에서 원하는 언어 선택 후에 다운로드 받으실 수 있습니다.

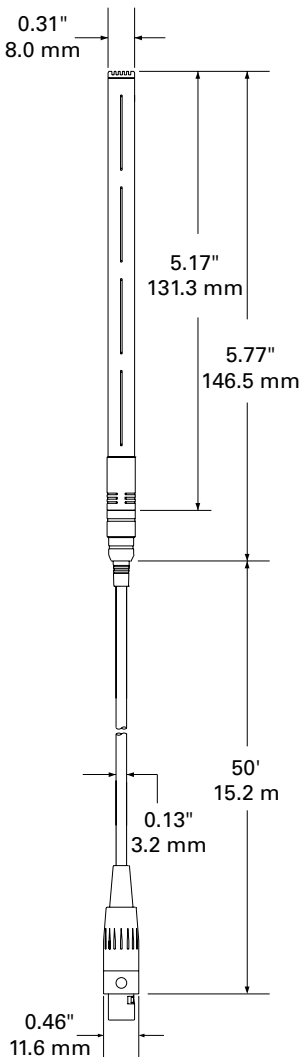

Specifications

Element	Fixed-charge back plate, permanently polarized condenser
Polar pattern	MicroLine® (line cardioid)
Frequency response	30-20,000 Hz
Open circuit sensitivity	-35 dB (17.7 mV) re 1V at 1 Pa
Maximum input sound level	133 dB SPL, 1 kHz at 1% T.H.D.
Dynamic range (typical)	109 dB, 1 kHz at Max SPL
Signal-to-noise ratio¹	70 dB, 1 kHz at 1 Pa
Weight	9.5 g (0.3 oz)
Dimensions	146.5 mm (5.77") long, 8.0 mm (0.31") head diameter
Output connector	TA3F-type
Cable	15.2 m (50') long (permanently attached to microphone), 3.2 mm (0.13") diameter, 2-conductor shielded cable, terminated with TA3F-type connector
Optional interchangeable elements	ESE-O omnidirectional (360°) ESE-C cardioid (120°) ESE-H hypercardioid (100°)
Audio-Technica case style	M14

Accessories furnished

ES933ML/MIC

AT8452 steel hanger; AT8138 two-stage foam windscreen

ES933WML/MIC

AT8452(WH) steel hanger; AT8138(WH) two-stage foam windscreen

Compatible power modules

AT8534 wall/ceiling plate power module; AT8538 power module; ATND8734a network audio microphone power module

Specifications derived by using AT8538 power module.

In the interest of standards development, A.T.U.S. offers full details on its test methods to other industry professionals on request.

1 Pascal = 10 dynes/cm² = 10 microbars = 94 dB SPL

¹ Typical, A-weighted, using Audio Precision System One.

Specifications are subject to change without notice.



frequency response: 30–20,000 Hz

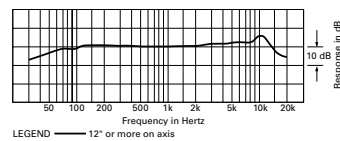

polar pattern

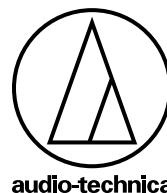
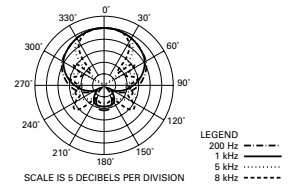

Audio-Technica Corporation
www.audio-technica.com
 ©2018 Audio-Technica