

# ES931H/MIC & ES931WH/MIC

## Hypercardioid Condenser Gooseneck Microphones



### Features

- **Uniform hypercardioid polar pattern with 100° acceptance angle**
- **Low-profile design with low-reflectance finish for minimum visibility**
- **Superior off-axis rejection for maximum gain before feedback**
- **UniGuard® RFI-shielding technology offers outstanding rejection of radio frequency interference (RFI)**
- **Easy-to-adjust, rugged, small-diameter gooseneck with virtually no “memory” permits quick positioning into desired shape**
- **Available interchangeable elements permit angle of acceptance from 90° to 360°**
- **Ideal for boardrooms, school and government settings, teleconferencing, houses of worship and other installed applications**
- **Available in two colors: black (ES931H/MIC) and white (ES931WH/MIC)**

### Description

The ES931H/MIC is a wide-range miniature condenser microphone with a hypercardioid polar pattern. It is designed for quality sound reinforcement. The small-diameter gooseneck design permits highly flexible positioning while maintaining a smooth, well-contoured appearance. The combination of small size and excellent response makes the microphone ideal for boardrooms, school and government settings, teleconferencing, houses of worship and other installed applications.

The microphone requires a compatible Audio-Technica power module (not included) for operation.

The microphone is equipped with UniGuard® RFI-shielding technology, which offers outstanding rejection of radio frequency interference (RFI).

The microphone's hypercardioid polar pattern provides a 100° angle of acceptance. Additional interchangeable elements with omnidirectional (360°), cardioid (120°) and MicroLine® (90°) pickup patterns are available.

The microphone's free end connects to a compatible Audio-Technica power module (not included) via a special TA3F-type connector designed to optimize RFI immunity.

The microphone is enclosed in a rugged housing with a low-reflectance black finish and comes equipped with a two-stage foam windscreen. It is also available with white housing and windscreen as the ES931WH/MIC.

### Installation and Operation

The ES931H/MIC requires a compatible Audio-Technica power module (not included) for operation.

A uniform 100° angle of acceptance provides well-balanced audio pickup. The microphone should be located forward of the front-most source, above the rear-most source, and “aimed” between them. Increasing the height of the mic above the sources will tend to equalize sound levels between them, but may also increase background/reverberant sound pickup. When possible, the distance from the mic to the rear-most source should be no more than twice the distance to the front source, to maintain front-to-rear balance.

Width of pickup is approximately 2.5 times the distance to the closest source. If additional mics are needed for wide sources, they should be positioned apart laterally at least 2.5 times the distance to the front source, to avoid phase cancellation (Fig. 1).

The provided two-stage foam windscreen simply snaps over the head of the microphone, effectively reducing noise from wind or ventilation air currents.

Avoid leaving the microphone in the open sun or in areas where temperatures exceed 110° F (43° C) for extended periods. Extremely high humidity should also be avoided.

**Note:** Audio-Technica has developed a special RFI-shielding mechanism, which is an integral part of the connectors in the Engineered Sound® line. If you remove or replace the connector, you may adversely affect the unit's RFI immunity.

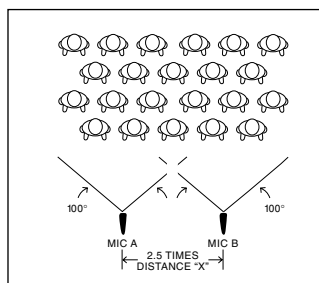

Figure 1

# ES931H/MIC & ES931WH/MIC

To reduce the environmental impact of a multi-language printed document, product information is available online at [www.audio-technica.com](http://www.audio-technica.com) in a selection of languages.

Afin de réduire l'impact sur l'environnement de l'impression de plusieurs langues, les informations concernant les produits sont disponibles sur le site [www.audio-technica.com](http://www.audio-technica.com) dans une large sélection de langues.

Para reducir el impacto al medioambiente, y reducir la producción de documentos en varios leguajes, información de nuestros productos están disponibles en nuestra página del Internet: [www.audio-technica.com](http://www.audio-technica.com).

Para reduzir o impacto ecológico de um documento impresso de várias linguas, a Audio-Technica providência as informações dos seus produtos em diversas linguas na [www.audio-technica.com](http://www.audio-technica.com).

Per evitare l'impatto ambientale che la stampa di questo documento determinerebbe, le informazioni sui prodotti sono disponibili online in diverse lingue sul sito [www.audio-technica.com](http://www.audio-technica.com).

Der Umwelt zuliebe finden Sie die Produktinformationen in deutscher Sprache und weiteren Sprachen auf unserer Homepage: [www.audio-technica.com](http://www.audio-technica.com).

Om de gevolgen van een gedrukte meertalige handleiding op het milieu te verkleinen, is productinformatie in verschillende talen "on-line" beschikbaar op: [www.audio-technica.com](http://www.audio-technica.com).

本公司基於減少對環境的影響，將不作多語言文件的印刷，有關產品訊息可在 [www.audio-technica.com](http://www.audio-technica.com) 的官方網頁上選擇所屬語言及瀏覽。

本公司基于减少对环境的影响，将不作多语言文档的印刷，有关产品信息可在 [www.audio-technica.com](http://www.audio-technica.com) 的官方网页上选择所属语言和浏览。

자원절약, 환경보호를 위해 국문 사용 설명서는 인쇄하지 않았습니다.  
제품정보는 [www.audio-technica.com](http://www.audio-technica.com) 에서 원하는 언어 선택 후에 다운로드 받으실 수 있습니다.

## Specifications

<b>Element</b>	Fixed-charge back plate, permanently polarized condenser
<b>Polar pattern</b>	Hypercardioid
<b>Frequency response</b>	80-20,000 Hz
<b>Open circuit sensitivity</b>	-40 dB (10.0 mV) re 1V at 1 Pa
<b>Maximum input sound level</b>	138 dB SPL, 1 kHz at 1% T.H.D.
<b>Dynamic range (typical)</b>	109 dB, 1 kHz at Max SPL
<b>Signal-to-noise ratio<sup>1</sup></b>	65 dB, 1 kHz at 1 Pa
<b>Weight</b>	39 g (1.4 oz)
<b>Dimensions</b>	152.4 mm (6.0") long (with capsule), 8.4 mm (0.33") head diameter, 11.6 mm (0.46") base diameter
<b>Output connector</b>	TA3F-type
<b>Optional interchangeable elements</b>	ESE-O omnidirectional (360°) ESE-C cardioid (120°) ESE-ML MicroLine® (90°)
<b>Audio-Technica case style</b>	M41
<b>Accessories furnished</b>	ES931H/MIC AT8109 two-stage foam windscreen ES931WH/MIC AT8109(WH) two-stage foam windscreen
<b>Compatible power modules</b>	AT8534 wall/ceiling plate power module; AT8538 power module; ATND8734 network audio microphone power module

Specifications derived by using AT8538 power module.

In the interest of standards development, A.T.U.S. offers full details on its test methods to other industry professionals on request.

1 Pascal = 10 dynes/cm<sup>2</sup> = 10 microbars = 94 dB SPL

<sup>1</sup> Typical, A-weighted, using Audio Precision System One.

Specifications are subject to change without notice.

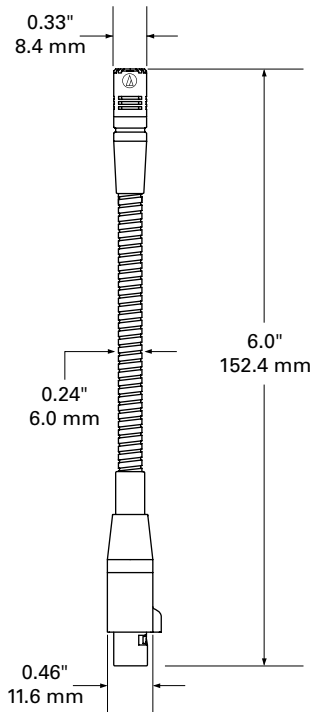

frequency response: 80–20,000 Hz

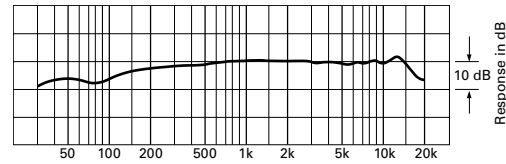

LEGEND — 12" or more on axis

polar pattern

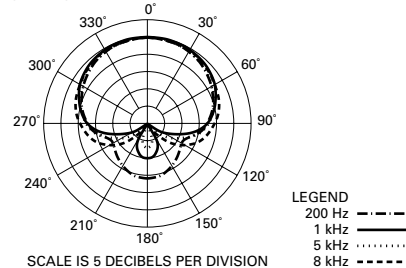

LEGEND  
200 Hz — — — — —  
1 kHz — — — — —  
5 kHz ·······  
8 kHz - · - · - ·  
SCALE IS 5 DECIBELS PER DIVISION

 **audio-technica**

Audio-Technica Corporation  
[audio-technica.com](http://audio-technica.com) ©2016 Audio-Technica

P52593-01