

SpectraPulse®

Ultra Wideband
Wireless Microphone System

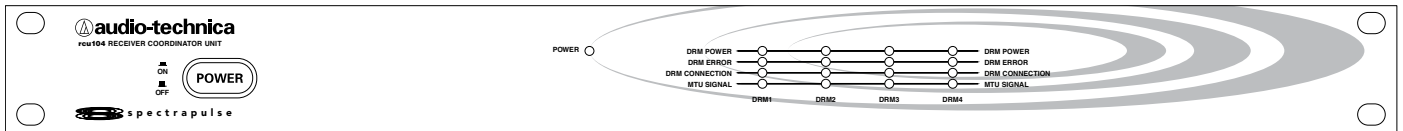

rcu104 Receiver Coordinator Unit



Set-up and Operation



CAUTION! Electrical shock can result from removal of SpectraPulse® components' covers. Refer servicing to qualified service personnel. No user-serviceable parts inside. Do not expose to rain or moisture. The circuits inside the SpectraPulse® components have been precisely adjusted for optimum performance and compliance with federal regulations. Do not attempt to open the rcu104 Receiver Coordinator Unit. To do so will void the warranty, and may cause improper operation.

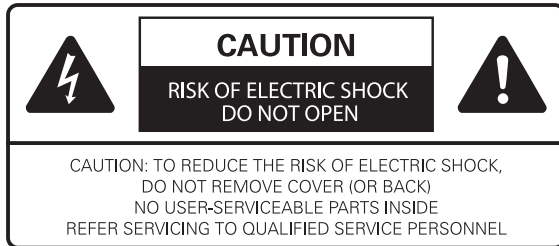

The lightning flash with arrowhead symbol within an equilateral triangle is intended to alert the user to the presence of uninsulated "dangerous voltage" within the product's enclosure that may be of sufficient magnitude to constitute a risk of electric shock to persons.



The exclamation point within an equilateral triangle is intended to alert the user to the presence of important operating and maintenance (servicing) instructions in the literature accompanying the product.

Warning: This apparatus must be grounded.

This product is a safety class 1 product. There must be an uninterruptible safety earth ground from the main power source to the product's AC input. Whenever it is likely that the protection has been impaired, disconnect the power cord until the ground has been restored. An apparatus with class 1 construction shall be connected to an AC outlet with a protective grounding connection.

This device complies with part 15 of the FCC Rules. Operation is subject to the condition that this device does not cause harmful interference.

This device complies with INDUSTRY CANADA R.S.S. 210, en conformité avec IC: RSS-210/CNR210.

Operation is subject to the following conditions:

- 1) This device may not cause harmful interference and
- 2) this device must accept any interference received, including interference which may cause undesired operation. Changes or modifications not expressly approved by Audio-Technica could void your authority to operate this equipment.

IMPORTANT SAFETY INSTRUCTIONS

- 1) Read these instructions.
- 2) Keep these instructions.
- 3) Heed all warnings.
- 4) Follow all instructions.
- 5) Do not use this apparatus near water.
- 6) Clean only with dry cloth.
- 7) Do not block any ventilation openings. Install in accordance with the manufacturer's instructions.
- 8) Do not install near any heat sources such as radiators, heat registers, stoves, or other apparatus (including amplifiers) that produce heat. Do not defeat the safety purpose of the polarized or grounding-type plug. A polarized plug has two blades with one wider than the other. A grounding type plug has two blades and a third grounding prong. The wide blade or the third prong are provided for your safety. If the provided plug does not fit into your outlet, consult an electrician for replacement of the obsolete outlet.
- 10) Protect the power cord from being walked on or pinched particularly at plugs, convenience receptacles, and the point where they exit from the apparatus.
- 11) Only use attachments/accessories specified by the manufacturer.
- 12) Use only with the cart, stand, tripod, bracket, or table specified by the manufacturer, or sold with the apparatus. When a cart is used, use caution when moving the cart/apparatus combination to avoid injury from tip-over.
- 13) Unplug this apparatus during lightning storms or when unused for long periods of time.
- 14) Refer all servicing to qualified service personnel. Servicing is required when the apparatus has been damaged in any way, such as power-supply cord or plug is damaged, liquid has been spilled or objects have fallen into the apparatus, the apparatus has been exposed to rain or moisture, does not operate normally, or has been dropped.



Note: This equipment has been tested and found to comply with the limits for a Class A digital device, pursuant to Part 15 of the FCC Rules. These limits are designed to provide reasonable protection against harmful interference when the equipment is operated in a commercial environment. This equipment generates, uses, and can radiate radio frequency energy and, if not installed and used in accordance with the instruction manual, may cause harmful interference to radio communications. Operation of this equipment in a residential area is unlikely to cause harmful interference. However, if the equipment does cause harmful interference, the user will be required to correct the interference at own expense.

Notice to individuals with implanted cardiac pacemakers or AICD devices:

Any source of RF (radio frequency) energy may interfere with normal functioning of the implanted device. All wireless microphones have low-power transmitters (less than 0.05 watts output) which are unlikely to cause difficulty, especially if they are at least a few inches away. **Note also that any medical-device disruption will cease when the RF transmitting source is turned off. Please contact your physician or medical-device provider if you have any questions, or experience any problems with the use of this or any other RF equipment.**

Please note that your SpectraPulse® system operates in a frequency band in a way which may make its use subject to certain FCC and other regulatory agency restrictions and licensing requirements. No changes or modifications may be made to this equipment except by the expressly approved responsible party for compliance. Changes or modifications could void the user's authority to operate the equipment, and will also void Audio-Technica warranty coverage. For further information, Please contact your local office of the FCC as applicable.

Contents

What's in the box	Page 3
Features	Page 3
Installation & Operation	Page 3
Front Panel Controls and Functions	Page 5
Rear Panel Controls and Functions	Page 6
Typical Configurations	Page 6
Specifications	Page 8

What's in the box:

- **rcu104 Receiver Coordinator Unit**
- **IEC power cable**
- **8" shielded Cat 5 cable with RJ45 connectors (for connecting to an aci707 unit)**

Note: See SpectraPulse® Owner's Manual for full system specifications.

rcu104 Receiver Coordinator Unit Features:

- **Strengthens UWB Connection** — Increases robustness of the Ultra Wideband connection by allowing use of up to four drm141 Digital Receiver Modules in a SpectraPulse system.
- **Expands Coverage Area** — Allows for expanded coverage of a SpectraPulse system through use of multiple drm's.
- **Allows Adjacency** — Permits two audio systems in side-by-side rooms to share a single SpectraPulse system.
- **Reduces Body-Shielding** — Enhances mtu performance by reducing body-shielding effects through use of multiple drm's.

rcu104 Receiver Coordinator Unit Installation & Operation

While a SpectraPulse system can operate with just a single drm141 Digital Receiver Module, it is often beneficial to expand coverage area and/or boost the robustness of the UWB connection beyond the range and signal strength that a single drm141 can provide. The SpectraPulse® rcu104 Receiver Coordinator Unit achieves this by allowing use of up to four drm141 Digital Receiver Modules in a SpectraPulse system.

The rcu104 receives the data streams from up to four drm141 modules and creates a single data stream that can be interpreted by up to two linked aci707 Audio Control Interface devices. For each connected drm141, the rcu104 Receiver Coordinator Unit also manages: UWB pulse timing, data coming from the aci707, and the correct programming of encryption keys. The rcu104 also allows a single SpectraPulse system to be shared by two closely located or co-located audio systems (in side-by-side conference rooms, for instance).

Use of the rcu104 and additional drm's does not increase the number of usable mtu's in a SpectraPulse system, which remains 14 in a system with two linked aci707 Audio Control Interface devices, and 7 in a system with a single aci707.

Note: Operation of rcu104 Receiver Coordinator Unit in the SpectraPulse system requires appropriate firmware for the drm141 and aci707. If you are adding the rcu104 to your existing SpectraPulse system, firmware on these components (drm141 and aci707) needs to be upgraded. Please contact Audio-Technica U.S. for a free firmware upgrade.

1. **Do not exceed the following maximum cable lengths:**
 - rcu104 – drm141: 500 ft.
 - rcu104 – aci707: 200 ft.
 - aci707 – aci707: 200 ft.

rcu104 Receiver Coordinator Unit Installation & Operation (continued)

2. Placement — Place the rcu104 and aci707 wherever convenient without exceeding maximum cable lengths. **Note: The rcu104 is not required to be in the same room as the drm141, but Audio-Technica recommends placement in close proximity to the aci707 system devices.**

Note: When multiple drm’s are used, there should be more than one drm per room. If the user places a single drm per room (using four drm’s to cover four rooms, for example), the performance (range/robustness) of the system link will be reduced.

3. Plug the rcu104 Receiver Coordinator Unit into the AC power source. (See Power Cord, page 6.) **Note: Make certain you do not turn on the power until after all the system connections are made.**

4. With the power off, connect the shielded Cat 5 cable exiting each drm141 (up to four) to the rcu104; the connection points are four RJ45 connections (labeled DRM 1 through 4) on the rear of the rcu104. **Note: Do not plug a Cat 5 cable into the rcu104 with the power on. Do not plug any Cat 5 cable from the rcu104 into an Ethernet port.**

5. Use the included Cat 5 cable to connect the Link Out on the rear of the rcu104 Receiver Coordinator Unit to the Link In on the aci707 Audio Control Interface. If using two aci707 units, loop from the first aci707’s Link Out to a second aci707’s Link In.

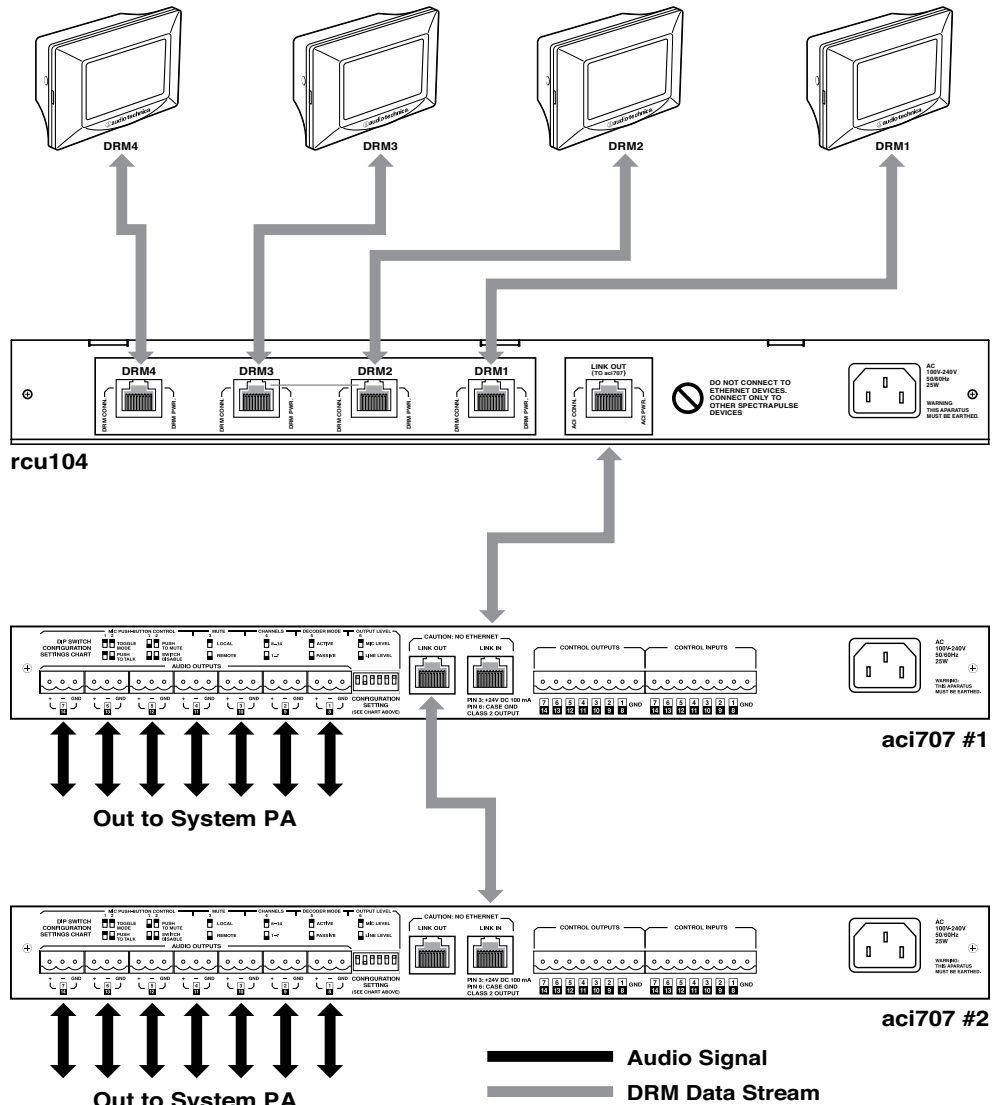

rcu104 Receiver Coordinator Unit Installation & Operation (continued)

6. Press the power button on the front panel of the rcu104. Confirm that the blue rcu104 power LED comes on. Confirm that the drm power (green) and drm connection (yellow) LED's are illuminated for each drm connected to the system. **Note: The rcu104 Receiver Coordinator Unit must be powered on whenever any part of the system is in use.**
7. Turn on at least one mtu. The rcu104 has an orange mtu signal LED for each of four drm141 Digital Receiver Modules that may be used in a SpectraPulse system. As you bring the mtu within each drm's reception area, this mtu signal LED on the front panel of the rcu104 will illuminate, confirming that each drm is receiving a signal. This feature can be used to help in the placement of drm141 Digital Receiver Modules for optimum signal coverage. If you find an area in which the mtu signal LED is not illuminated, adjust placement of the drm141 to achieve optimum coverage.
8. If the "DRM ERROR" LED is illuminated, invalid (outdated) firmware has been detected on a connected drm141; in this case, please contact Audio-Technica U.S. for a free firmware upgrade.

Note: Under normal start-up conditions, all green LED's on the front and rear panels of the rcu104 will indicate power is provided to all the drm141 ports (DRM 1-4). If no drm141 is currently connected to a particular port, the firmware will detect this condition and turn power off at any unused port. All LED's will then extinguish on any unused port. If any port is deactivated during start-up sequencing, the system will need to be restarted in order to activate additional drm141 units. In this case, turn the rcu104 Receiver Coordinator Unit power switch off and then on to restart.

rcu104 Receiver Coordinator Unit Front Panel Controls and Functions

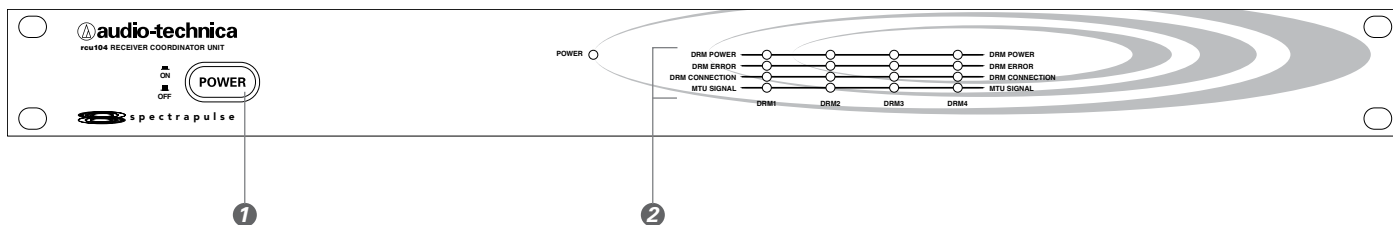

Press this button in to turn the unit on; the rcu104 Receiver Coordinator Unit blue power LED **1** *Power Switch* will light. Press again to turn the unit off. **Note: Since the unit uses a single pole on/off switch, the unit is not fully disconnected from mains power when the unit is off.**

There are four vertical columns and four horizontal rows of LED indicators. The four vertical LED **2** *LED Indicators* columns correspond to the four drm141 connections on the back of the rcu104, numbered 1 - 4.

Four horizontal rows of LEDs provide the following information:

DRM POWER (green LED):	The "DRM POWER" LED is illuminated when power is supplied to the drm port.
DRM ERROR (red LED):	The "DRM ERROR" LED is illuminated when invalid (out dated) firmware has been detected on a connected drm141; please contact Audio-Technica for drm firmware upgrade procedure.
DRM CONNECTION (yellow LED):	The "DRM CONNECTION" LED is illuminated when the drm141 is detected and communicating properly.
MTU SIGNAL (orange LED):	The "MTU SIGNAL" is illuminated when the corresponding drm141 is receiving a signal from at least one mtu.

rcu104 Receiver Coordinator Unit Rear Panel Controls and Functions

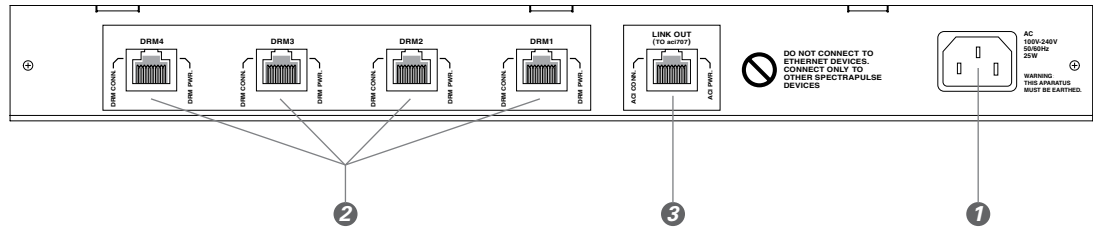

Power Cord 1 The rcu104 Receiver Coordinator Unit operates via the safety-approved IEC power cord supplied for connection to 110/120V AC 50/60Hz power. You must change to an approved power cord for operation in non-U.S. locations (in which case, the rcu104 will operate properly from 100/240V AC 50/60Hz). **Note: The power cord must be connected to a mains socket that has a protective earth connection.**

drm RJ45 Connectors 2 Connect up to four drm141 Digital Receiver Modules to the rcu104. With the power off, connect the shielded Cat 5 cable exiting each drm141 (up to four) to one of the rcu104's four RJ45 connections labeled DRM 1 through 4. **Note: Make certain rcu104 power is off before connecting or disconnecting the cable. Note: This is not an Ethernet connection, do not plug cable from the rcu104 into an Ethernet port.**

Link-Out RJ45 Connector (to aci707) 3 To link to your aci707, connect the provided 8" shielded Cat 5 cable from the rcu104 Link-Out RJ45 connector to the Link-In RJ45 connector on the aci707 intended for channels 1-7. **Again, remember this is not for Ethernet connection.**

rcu104 Receiver Coordinator Unit Typical Configurations

One Room

- Up to four drm's can be used for expanded coverage areas.
- Use of more than one drm requires use of an rcu104 Receiver Coordinator Unit and upgraded drm firmware.
- Up to 14 mtu's can be used at one time.

Two Rooms

- Two drm's should be used in each room for expanded coverage areas.
- Requires coordinator and upgraded drm firmware.
- Up to 14 mtu's (total, in all rooms) can be used at one time.

Three / Four Rooms

- A three- or four-room configuration is possible, but is not recommended due to reduced coverage area.

rcu104 Receiver Coordinator Unit Typical Configurations (continued)

One-room Configuration

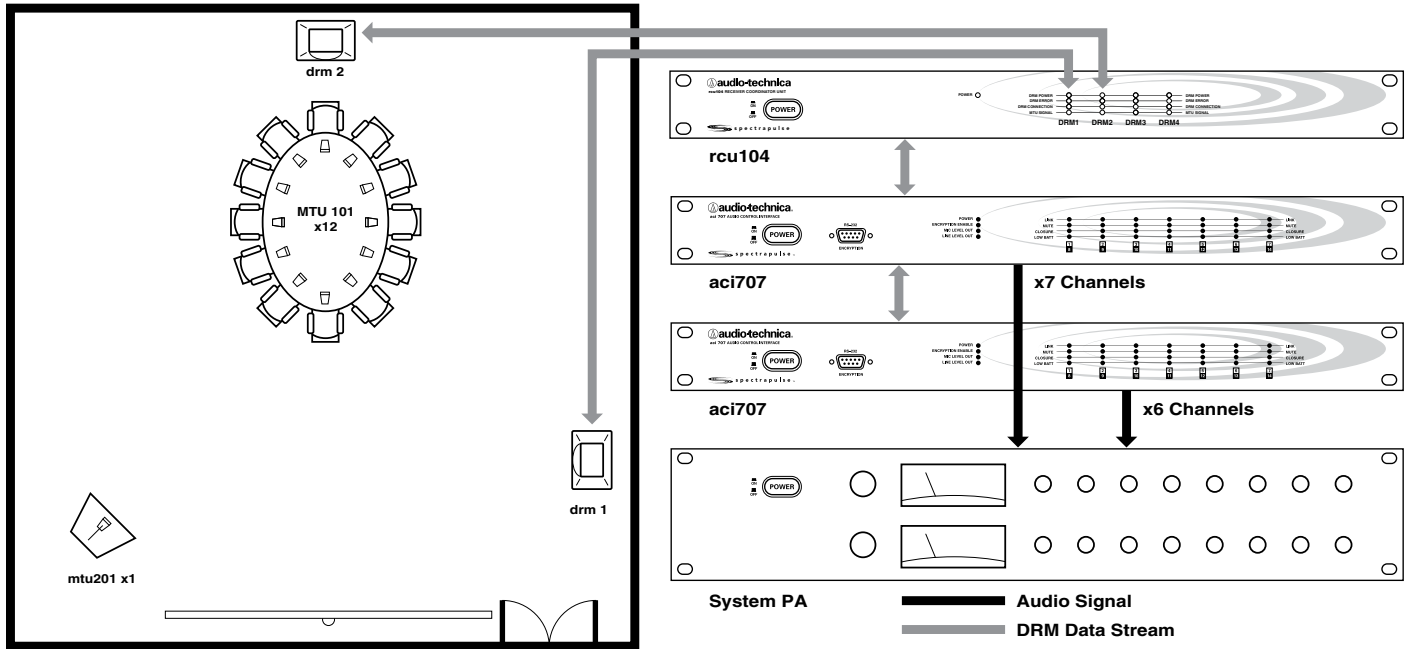

The rcu104 with multiple drm's can be used to expand coverage area of the SpectraPulse system. Experiment with placement of the drm141 Digital Receiver Modules for optimal coverage. It may be helpful to watch the mtu signal LED for each separate drm to make certain you are getting a signal. Since the drm's will reinforce each other, the rcu104 permits you to extend coverage to a large space — including ballrooms and irregularly shaped rooms.

Two-room Configuration

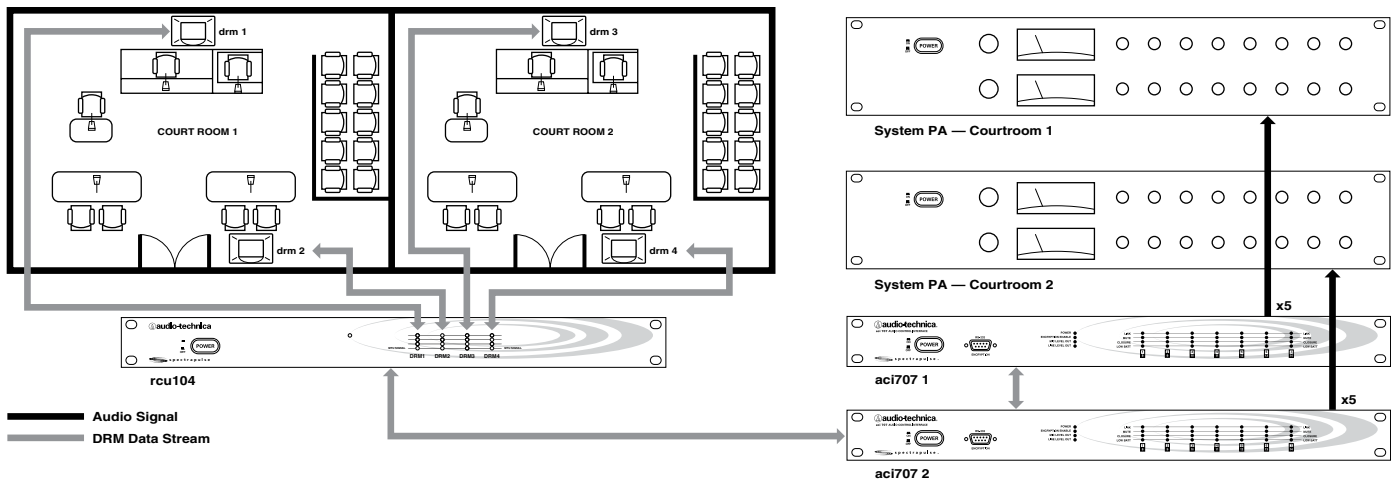

This example shows a SpectraPulse system used with two co-located but separate audio systems. Two drm141 Digital Receiver Modules are located in each of the two rooms, 5 mtu's are located in each room (up to seven mtu's would be possible in each room). The four drm's are all connected to the rcu104 which sends the mtu signals to aci707 Audio Control Interface devices 1 and 2. Note that aci 1 is connected to the audio system in room one, while aci 2 is connected to the audio system in room two. The mtu's in room one are set to channels 1-5; mtu's in room two are set to channels 8-12. Without use of the rcu104 Receiver Coordinator Unit, only one drm could be used; it would not provide adequate coverage for this installation.

rcu104 Receiver Coordinator Unit Specifications†

Power Input	100 – 240V AC, 50/60 Hz
Current Consumption	25 W
Cable Length	
drm to rcu	152 m (500') maximum
rcu to aci	60 m (200') maximum
aci to aci	60 m (200') maximum
Dimensions	480.0 mm (19.00") W x 45.7 mm (1.80") H x 193.8 mm (7.63") D
Weight	2.0 kg (4.5 lbs)

† Specifications are subject to change without notice.

Five-Year Limited Warranty

From and after August 1, 2009, Audio-Technica U.S. Engineered Sound® wired microphones, Engineered Sound® wireless microphone systems and wireless microphone system components, and "ES" designated accessories purchased in the U.S.A. are warranted for five years from date of purchase by Audio-Technica U.S., Inc. (A.T.U.S.) to be free of defects in materials and workmanship. In the event of such defect, product will be repaired promptly without charge or, at our option, replaced with a new product of equal or superior value if delivered to A.T.U.S. or an authorized Service Center, prepaid, together with the sales slip or other proof of purchase date. This warranty excludes defects due to normal wear, abuse, shipping damage, or failure to use product in accordance with instructions. This warranty is void in the event of unauthorized repair or modification, or removal or defacing of the product labeling.

For U.S. service return instructions and procedure please go to:
www.audio-technica.com/returninstructions

A.T.U.S. WARRANTY IS TO THE END USER ONLY. EXCEPT FOR A.T.U.S.' SAID EXPRESS WARRANTY TO THE END USER, A.T.U.S. MAKES NO WARRANTIES, EXPRESS OR IMPLIED, WITH RESPECT TO THE GOODS, THEIR USE, PERFORMANCE, FITNESS FOR A PARTICULAR PURPOSE OR MERCHANTABILITY TO ANYONE. A.T.U.S. NEITHER ASSUMES NOR AUTHORIZES ANY PERSON TO ASSUME FOR A.T.U.S. ANY WARRANTY, EXPRESS OR IMPLIED.

A.T.U.S. IS NOT LIABLE OR RESPONSIBLE FOR ANY DIRECT, INDIRECT, CONSEQUENTIAL, INCIDENTAL OR SPECIAL DAMAGES ARISING DIRECTLY OR INDIRECTLY IN RESPECT OF SUCH GOODS OR THE USE OR FAILURE OF SUCH GOODS, WHETHER BASED UPON BREACH OF WARRANTY, NEGLIGENCE, STRICT LIABILITY IN TORT OR OTHERWISE, AND THE SOLE AND EXCLUSIVE REMEDY FOR ANY LOSS INCURRED WITH RESPECT TO THE GOODS IS AT A.T.U.S.' ELECTION, THE COST OF REPAIR, REFUND OF THE SELLING PRICE, WHETHER IN THE FORM OF A CREDIT WITH A.T.U.S. OR CASH, OR REPLACEMENT OF THE GOODS. IT IS FURTHER AGREED AND UNDERSTOOD THAT THE PRICE OF THE GOODS IDENTIFIED IS CONSIDERATION FOR LIMITING A.T.U.S. LIABILITY. A.T.U.S. IS NOT LIABLE FOR DELAY IN PERFORMANCE OR NONPERFORMANCE OF THIS AGREEMENT BY A.T.U.S. DUE TO ANY CAUSE BEYOND A.T.U.S.' CONTROL.

Outside the U.S.A., please contact your local dealer for warranty details.



Audio-Technica U.S., Inc.
1221 Commerce Drive, Stow, Ohio 44224 (330) 686-2600
www.audio-technica.com