



DESCRIPTION

The ES935H6 is a wide-range miniature condenser microphone with a hypercardioid polar pattern. It is designed for quality sound reinforcement, professional recording, television and other demanding sound pickup applications. The small-diameter gooseneck design permits highly flexible positioning while maintaining a smooth, well-contoured appearance. An included snap-on foam windscreen effectively reduces wind noise and "popping."

The ES935H6 is equipped with UniGuard® RFI-shielding technology, which offers outstanding rejection of radio frequency interference (RFI). The microphone is RoHS compliant – free from all substances specified in the EU directive on hazardous substances.

The microphone's hypercardioid polar pattern provides a 100° angle of acceptance. Additional interchangeable elements with omnidirectional (360°), cardioid (120°) and MicroLine® (90°) pickup patterns are available.

The integral power module can be powered from any external 11V to 52V DC phantom power supply. A recessed switch in the power module permits choice of flat response or low-frequency roll-off (via integral 80 Hz high-pass UniSteep® filter) to help control undesired ambient noise.

The microphone is enclosed in a rugged housing with a low-reflectance black finish. It features an XLRM-type connector insert at its base, allowing it to be plugged directly into an XLRM-type panel jack or microphone cable. In addition to an AT8474 low-profile isolation mount, an AT8473 stand clamp is included to permit attachment of the XLR mic base to a standard 5/8"-27 or 3/8"-16 threaded mic stand or mounting flange.

The microphone is enclosed in a rugged housing with a low-reflectance black finish. It features an XLRM-type connector insert at its base, allowing it to be plugged directly into an XLRM-type panel jack or microphone cable. In addition to an AT8474 low-profile isolation mount, an AT8473 stand clamp is included to permit attachment of the XLR mic base to a standard 5/8"-27 or 3/8"-16 threaded mic stand or mounting flange.

INSTALLATION AND OPERATION

The ES935H6 requires 11V to 52V phantom power for operation.

Output is low impedance balanced. The output connector mates with XLRM-type cable connectors. The balanced signal appears across Pins 2 and 3, while the ground (shield) connection is Pin 1. Output is phased so that positive acoustic pressure produces positive voltage at Pin 2, in accordance with industry convention.

The microphone can be mounted on a podium or desktop with the included AT8474 low-profile isolation mount. Designed to be mounted either above or beneath the mounting surface, the AT8474 firmly secures the microphone while providing maximum attenuation of noise, shock and vibration transmitted through the mounting surface. Installation details are provided on the back of this sheet. An AT8473 stand clamp is also included to permit attachment of the XLR mic base to a standard 5/8"-27 or 3/8"-16 threaded mic stand or mounting flange.

The provided snap-on foam windscreen simply slips over the element, effectively reducing wind noise and "popping."

An integral 80 Hz high-pass UniSteep® filter provides easy switching from a flat frequency response to a low-end roll-off. The roll-off position reduces the pickup of low-frequency ambient noise (such as traffic, air-handling systems, etc.), room reverberation and mechanically coupled vibrations. To engage the UniSteep® filter, use the end tip of a paperclip or other small pointed instrument to slide the switch toward the "bent" line.

While a modern condenser microphone is not unduly sensitive to the environment, temperature extremes can be harmful. Exposure to high temperature can result in gradual and permanent reduction of the output level. Avoid leaving the microphone in the open sun or in areas where temperatures exceed 110° F (43° C) for long periods of time. Extremely high humidity should also be avoided.

ARCHITECTS AND ENGINEERS SPECIFICATIONS

The microphone shall be a fixed-charge condenser designed for permanent installation or portable applications. It shall have a hypercardioid polar pattern with uniform 100° angle of acceptance and shall be capable of accepting optional interchangeable elements for additional polar patterns. It shall have a frequency response of 80 Hz to 20,000 Hz and be capable of handling sound input levels up to 138 dB with a dynamic range of 109 dB. Nominal open-circuit output voltage shall be 10.0 mV at 1 kHz, 1 Pascal. Output shall be low impedance balanced (250 ohms).

The microphone shall operate from an external 11V to 52V DC phantom power source. It shall offer outstanding rejection of radio frequency interference (RFI). The microphone shall be RoHS compliant.

The microphone shall be a gooseneck design permitting highly flexible positioning and noiseless operation. It shall incorporate a self-contained power module with an XLRM-type connector at the base for direct connection to a mating XLRM-type panel jack or cable connector. The power module shall include a recessed switch for low-frequency roll-off. The low-frequency roll-off shall be a tailored roll-off at 80 Hz to minimize pickup of unwanted mechanical noise.

A universal isolation-type shock mount suitable for above or below surface installation shall be supplied for mounting the microphone in a solid surface. It shall be possible to firmly secure the microphone in the mount. The mount shall include appropriate hardware for installation. For alternative mounting and portable applications, the microphone shall be supplied with a stand clamp to permit attaching the microphone directly to a standard 5/8"-27 or 3/8"-16 thread. A snap-on foam windscreen shall also be included.

The microphone shall be a small-diameter gooseneck design, with an overall length of 7.77" (197.3 mm). Head diameter shall be 0.33" (8.4 mm). The microphone weight shall be 3.7 oz (104 grams). Finish shall be low reflectance black.

The Audio-Technica ES935H6 is specified.

AT8474 LOW-PROFILE ISOLATION MOUNT INSTALLATION INSTRUCTIONS

MOUNTING DIMENSIONS

- 1/16" (1.5 mm) pilot holes 3 places on 1.57" (40.0 mm) circle.
- 1.00" (25.4 mm) hole through the mounting surface.
- Outside edge of mount, 2.06" (52.4 mm) diameter.

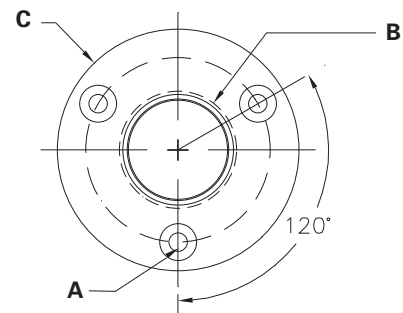

Drawing not actual size.

1. The AT8474 mount can be mounted either above or below the table surface.
2. Locate the center of the mounting location and mark it. **Allow enough clearance to accommodate the AT8474 mount on the desired surface and make certain there are no physical obstructions below the desired location.**
3. Locate the three mounting screw holes and mark them.

Continued on back.

4. Using a 1" hole saw, drill the through-hole for the microphone body. (Note: although a 1" drill bit will work, a hole saw provides for a cleaner hole and is less likely to damage the table surface.)
5. Using a 1/16" (1.5 mm) drill bit, drill three pilot holes for the mounting screws. (If mounting below the table surface, be certain **NOT** to drill pilot holes through the table.)
6. Place the AT8474 mount over the hole and partially tighten the three screws. Then place the microphone in the AT8474 so that the microphone's power module (base) extends through the AT8474 mount into the hole. Tighten all three screws evenly. For maximum security, the screws should be tight enough to ensure that the microphone is held securely in place and can not be removed without loosening the screws.
7. If mounting the AT8474 mount below the surface of the table, slide the rubber trim ring over the microphone (above the table surface) and seat it between the microphone and the sides of the hole for a finished appearance. (If mounting the AT8474 above the surface of the table, you may also choose to use the trim ring beneath the surface of the table, for added attenuation of noise, shock and vibration.)
8. After installing the microphone, assure maximum shock mount effectiveness by providing some slack in the connecting cable. The cable can be secured to the table with a standard wire clip or cable tie (not included).

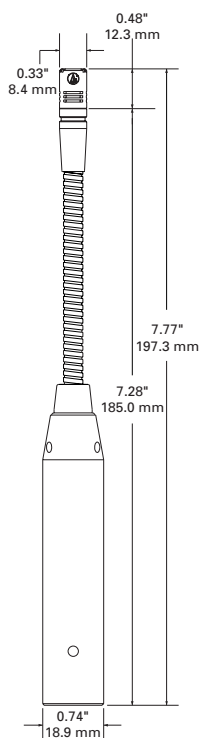

ES935H6 SPECIFICATIONS*

ELEMENT	Fixed-charge back plate permanently polarized condenser
POLAR PATTERN	Hypercardioid
FREQUENCY RESPONSE	80-20,000 Hz
LOW-FREQUENCY ROLL-OFF	80 Hz, 18 dB/octave
OPEN CIRCUIT SENSITIVITY	-40 dB (10.0 mV) re 1V at 1 Pa*
IMPEDANCE	250 ohms
MAXIMUM INPUT SOUND LEVEL	138 dB SPL, 1 kHz at 1% T.H.D.
DYNAMIC RANGE (typical)	109 dB, 1 kHz at Max SPL
SIGNAL-TO-NOISE RATIO[†]	65 dB, 1 kHz at 1 Pa*
SWITCH	Flat, roll-off
PHANTOM POWER REQUIREMENT	11-52V DC, 4 mA typical
WEIGHT	104 g (3.7 oz)
DIMENSIONS	197.3 mm (7.77") long, 8.4 mm (0.33") head diameter, 18.9 mm (0.74") base diameter
OUTPUT CONNECTOR	Integral 3-pin XLRM-type
OPTIONAL INTERCHANGEABLE ELEMENTS	ESE-O omnidirectional (360°); ESE-C cardioid (120°); ESE-ML MicroLine® (90°)
ACCESSORIES FURNISHED	AT8109 two-stage foam windscreen; AT8474 universal isolation mount; AT8473 quick-mount stand adapter; 5/8"-27 to 3/8"-16 threaded adapter

†In the interest of standards development, A.T.U.S. offers full details on its test methods to other industry professionals on request.

*1 Pascal = 10 dynes/cm² = 10 microbars = 94 dB SPL

[†] Typical, A-weighted, using Audio Precision System One.

Specifications are subject to change without notice.

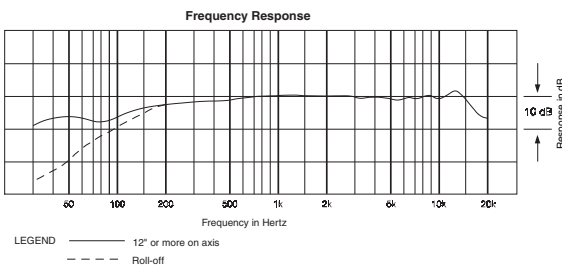
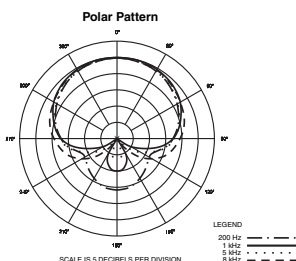

Audio-Technica U.S., Inc., 1221 Commerce Drive, Stow, Ohio 44224
Audio-Technica Limited, Old Lane, Leeds LS11 8AG England
www.audio-technica.com

P51932 ©2007 Audio-Technica U.S., Inc. Printed in U.S.A.