



ES925ML6/DS5
ES925ML12/DS5
ES925ML15/DS5
ES925ML18/DS5
ES925ML21/DS5
ES925ML24/DS5

User Manual
MICROLINE CONDENSER
MODULAR GOOSENECK MICROPHONE
WITH 5-PIN DESK STAND POWER MODULE



audio-technica

■ Introduction

Thank you for purchasing this product. Before using the product, read through the user manual to ensure that you will use the product correctly. Please keep this manual for future reference.

■ Features

- Modular microphone system comprised of an ES Series capsule, gooseneck assembly, and power module.
- RGB LEDs built into both the desk stand power module and gooseneck assembly indicate the on/off status of the microphone.
- Includes external control function for device control from the capacitive touch switch.
- The capacitive touch switch can be set to any of three operating modes: "touch-on/touch-off", "touch-to-talk" and "touch-to-mute".

■ Safety precautions

Although this product was designed to be used safely, failing to use it correctly may result in an accident. To ensure safety, observe all warnings and cautions while using the product.

■ Cautions for the product

- Do not subject the product to strong impact to avoid malfunction.
- Do not disassemble, modify or attempt to repair the product.
- Do not handle the product with wet hands to avoid electric shock or injury.
- Do not store the product under direct sunlight, near heating devices or in a hot, humid or dusty place.

■ Notes on use

- Do not swing or pull the product. Doing so may cause disconnection or damage.
- The circuitry in the microphone takes about 30 seconds to stabilize after power is supplied. You may hear some audio disturbance during startup.
- The connectors are equipped with a special RFI-shielding mechanism. If you remove or replace the connector, you may adversely affect the microphone's RFI immunity. The Audio-Technica Crimp Tool (ATCT) and shield parts are required to shorten the cable and reinstall the connector while maintaining the RFI immunity.
- Install the microphone on a flat, unobstructed mounting surface. Make sure that the sound source is not below the mounting surface.
- Depending on the surface finish of a table, the desk stand power module may leave marks on the table.
- Do not excessively bend the gooseneck assembly, rotate the ends of the capsule, or pull on them. Doing so may cause disconnection or malfunction.
- The product is a modular system comprised of a microphone element, gooseneck assembly and power module. Make sure the parts are firmly attached before use.
- Do not remove the rubber O-ring on the power module connecting part at the lower section of the gooseneck assembly.
- When attaching parts, remove the black cap on the capsule connecting part of the gooseneck assembly. **Do not remove the silicone part at the end of the capsule connecting part.**



■ Switch settings

To reduce low-frequency ambient noise (such as footsteps or air conditioning noise), room reverberation, and mechanically coupled vibrations as much as possible, turn on the low-cut filter switch (☑) on the bottom of the power module.

■ Assembly

- Insert the gooseneck assembly (c) while rotating it into the desk stand power module (d).
 - Tighten until it does not rotate, and use the hex wrench (h) to tighten the set screw (g) and set the gooseneck assembly in place.
 - Connect the capsule (b) to the gooseneck assembly, and attach the windscreen (a).
- * If the parts are not sufficiently tightened together, problems may occur such as the LED colors of the gooseneck assembly and power module not matching or sound is not output.

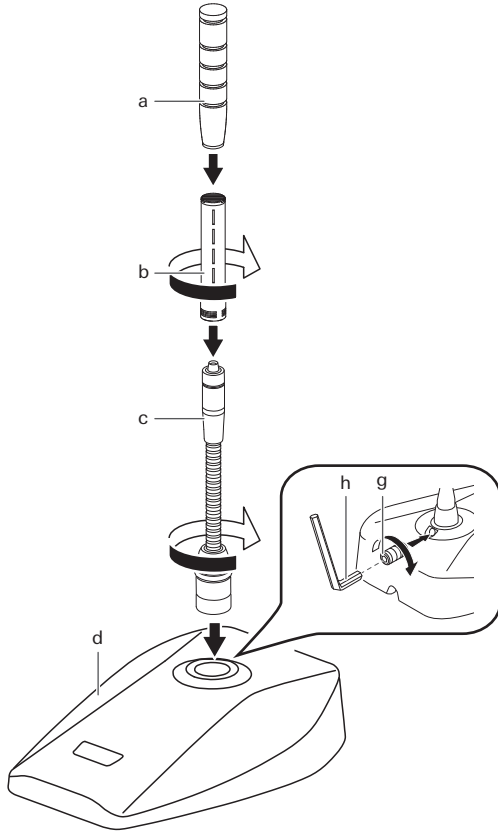

- Connect the included cable to the connector (e) on the reverse side of the desk stand power module, and pass the cable through the wire slot (f).

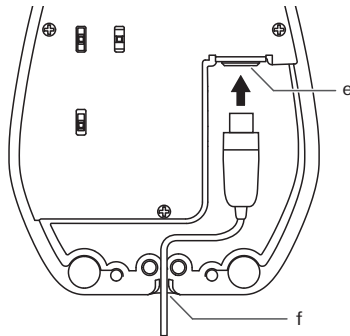

■ LED color

▼	1	2	3
OFF	RED	GREEN	YELLOW
4	5	6	7
BLUE	MAGENTA	CYAN	WHITE

■ Wiring

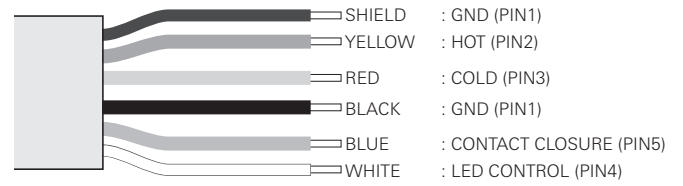
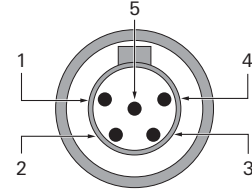

■ Switch setting and functions

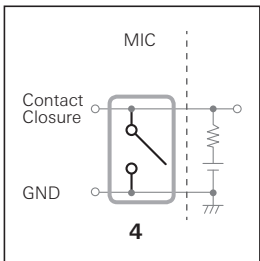
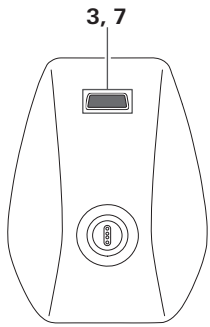
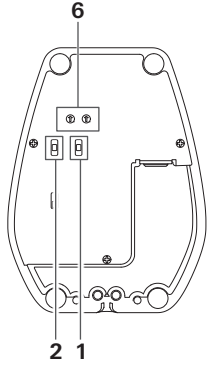

1. Control	2. Switch Function	3. Action	4. Contact closure status	5. Audio status	6. LED color	7. LED status	
<p>CONTROL</p> <p>LOCAL <input type="checkbox"/></p> <p>REMOTE <input type="checkbox"/></p> <p>LED REMOTE <input type="checkbox"/></p>	<p>SW.FUNCTION</p> <p>TOUCH ON/OFF <input type="checkbox"/></p> <p>MOM.ON <input type="checkbox"/></p> <p>MOM.OFF <input type="checkbox"/></p>				MIC OFF	MIC ON	
					MIC OFF	MIC ON	
					MIC OFF	MIC ON	
					MIC OFF	MIC ON	
					MIC OFF	MIC ON	
					MIC OFF	MIC ON	
	<p>CONTROL</p> <p>LOCAL <input type="checkbox"/></p> <p>REMOTE <input type="checkbox"/></p> <p>LED REMOTE <input type="checkbox"/></p>	<p>SW.FUNCTION</p> <p>TOUCH ON/OFF <input type="checkbox"/></p> <p>MOM.ON <input type="checkbox"/></p> <p>MOM.OFF <input type="checkbox"/></p>				MIC OFF	MIC ON
						MIC OFF	MIC ON
						MIC OFF	MIC ON
						MIC OFF	MIC ON
						MIC OFF	MIC ON
						MIC OFF	MIC ON
<p>CONTROL</p> <p>LOCAL <input type="checkbox"/></p> <p>REMOTE <input type="checkbox"/></p> <p>LED REMOTE <input type="checkbox"/></p>	<p>SW.FUNCTION</p> <p>TOUCH ON/OFF <input type="checkbox"/></p> <p>MOM.ON <input type="checkbox"/></p> <p>MOM.OFF <input type="checkbox"/></p>				MIC OFF	MIC ON	
					MIC OFF	MIC ON	
					MIC OFF	MIC ON	
					MIC OFF	MIC ON	
					MIC OFF	MIC ON	
					MIC OFF	MIC ON	

■ Specifications

ES925MLx/DS5

x = 6/12/15/18/21/24

Element	Fixed-charge back plate, permanently polarized condenser
Polar pattern	Line + Gradient
Frequency response	30 - 20,000 Hz
Low frequency roll-off	80 Hz, 18 dB/octave
Open circuit sensitivity	-35 dB (17.7mV) (0dB=1V/Pa, 1kHz)
Impedance	130 ohms
Maximum input sound level	137 dB SPL (1kHz at 1% THD)
Dynamic range	114 dB (1kHz at Max SPL)
Signal-to-noise ratio	71 dB (1kHz at 1Pa, A-weighted)
Switches	Low cut: on/off; Switch function: touch on/off, momentary on, momentary off; Control: local, remote, LED remote
Phantom power requirements	22 - 52 V DC, 8 mA
Contact closure	
Closure input voltage	-0.5 - 5.5 V
Maximum permissible power	200 mW
On-resistance	100 ohms
LED control	Active high (+5 V DC) TTL compatible
Active low voltage	1.2 V or lower
Maximum permissible input power	-0.5 - 5.5 V
Maximum permissible power	200 mW
Weight	ES925ML6/DS5: 678.2 g (23.9 oz) ES925ML12/DS5: 702.2 g (24.8 oz) ES925ML15/DS5: 707.2 g (24.9 oz) ES925ML18/DS5: 712.2 g (25.1 oz) ES925ML21/DS5: 717.2 g (25.3 oz) ES925ML24/DS5: 722.2 g (25.5 oz)
Dimensions	ES925ML6/DS5: 269.5 mm (10.6") x 97 mm (3.8") x 130 mm (5.1") ES925ML12/DS5: 377 mm (14.8") x 97 mm (3.8") x 130 mm (5.1") ES925ML15/DS5: 453.2 mm (17.8") x 97 mm (3.8") x 130 mm (5.1") ES925ML18/DS5: 529.4 mm (20.8") x 97 mm (3.8") x 130 mm (5.1") ES925ML21/DS5: 605.6 mm (23.8") x 97 mm (3.8") x 130 mm (5.1") ES925ML24/DS5: 681.8 mm (26.8") x 97 mm (3.8") x 130 mm (5.1") (HxWxD)
Output connector	TB5M-type
Optional interchangeable elements	ESE-Ca (120°), ESE-Ha (100°), ESE-Oa (360°)

Included accessories
7.6 m (24.9') Microphone cable (TA5F, unterminated),
Windscreen AT8138a,
Set screw (M2x4 mm (0.2")) 2 pcs., Hex wrench (0.89 mm (0.04"))

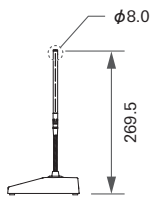

ES925ML6/DS5

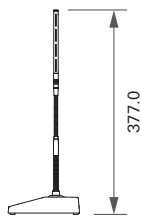

ES925ML12/DS5

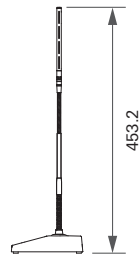

ES925ML15/DS5

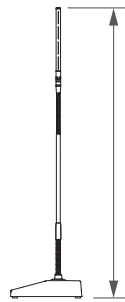

ES925ML18/DS5

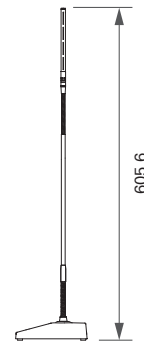

ES925ML21/DS5

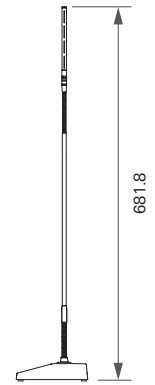

ES925ML24/DS5

(unit: mm)

■ Polar pattern

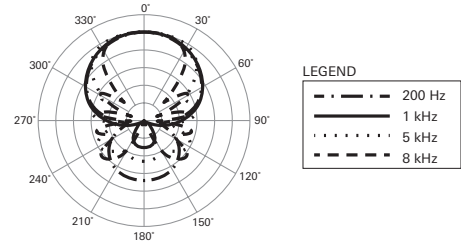

SCALE IS 5 DECIBELS PER DIVISION

■ Frequency response

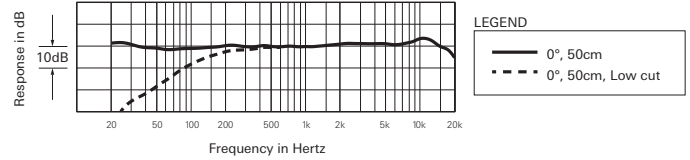

■ Dimensions

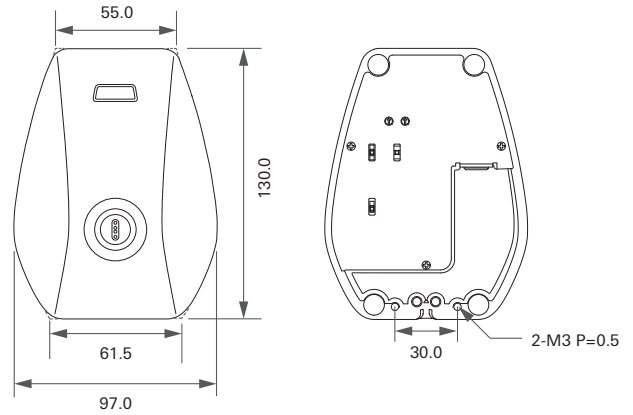

ES8766RC (DS5)