

## UHF SYNTHESIZED DIVERSITY RECEIVER

# ATW-R6200 S

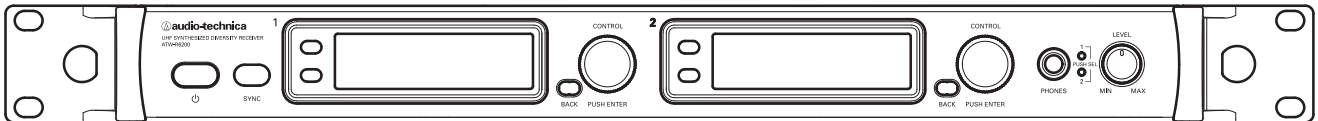

Thank you for purchasing this product.

Before using the product, take time to read this user manual thoroughly to ensure that you will use the product correctly. Also keep this user manual handy, along with the warranty, so that they are always available for reference.

## Features

- Uses advanced IMD suppression techniques to allow 31 simultaneous channels within a 4 MHz tuning bandwidth
- High-performance filtering removes external noise from outside of the tuning bandwidth
- Clear, easy-to-read display
- Easy transmitter setup via IR sync
- Headphone output jack for monitoring receiver output
- Ethernet connection allows monitoring and controlling via a PC
- Ethernet interface for monitoring and controlling system parameters via a PC
- Metal full-rack receiver chassis with reinforced mounting ears and rear rack mount capability

## Contents

Features .....	1
Important information .....	3
Notes on use .....	4
Using multiple wireless systems .....	4
Maintenance .....	4
Part names and functions <front panel> .....	5
Part names and functions <rear panel> .....	6
Part names and functions <display> .....	7
Minimum hold function .....	8
System operation .....	8
Settings .....	9
Main menu .....	9
Items configurable from the main menu .....	9
Setting the operating frequency .....	10
Setting the name .....	10
Correcting characters .....	11
Setting the squelch level .....	11
Setting the audio output level .....	11
Setting the line and mic levels .....	12
Setting the system-related functions .....	12
Setting the key lock .....	12
Setting the lock code .....	13
Setting the antenna power .....	13
Setting transmitters via IR sync .....	14
Screen saver settings .....	14
Resetting factory defaults .....	15
Checking the product information .....	15
Setting up the network .....	16
Obtaining an IP address .....	16
Setting the IP address .....	16
Setting the subnet mask .....	17
Displaying the MAC address .....	17
Changing the DHCP server setting .....	17
Setting up transmitter via IR sync .....	18
Using the key lock function .....	19
Setting up the key lock function .....	19
Cancelling the key lock function .....	19
Making connections (basic connections) .....	20
Example using an external antenna (sold separately) .....	21
Achieving stable reception .....	21
Front antenna connections .....	22
Rack mounting receivers .....	22
Specifications .....	23
Dimensions .....	23

# Important information



## Warning:

- To prevent fire or shock hazard, do not expose this apparatus to rain or moisture.

## Caution:

- Do not expose this apparatus to drips or splashes.
- To avoid electric shock, do not open the cabinet.
- Refer servicing to qualified personnel only.
- Do not expose this apparatus to excessive heat such as sunshine, fire or the like.
- Do not subject this apparatus to strong impact.
- This apparatus should be located close enough to the AC outlet so that you can easily grasp the power cord plug at any time.
- In case of emergency, disconnect the power cord plug of this apparatus quickly.
- Do not place any objects filled with liquids, such as vases, on this apparatus.
- To prevent fire, do not place any naked flame sources (such as lighted candles) on this apparatus.
- Do not install this apparatus in a confined space such as a bookcase or similar unit.
- Install this apparatus only in places with good ventilation.
- To prevent fire, do not cover the vents of this apparatus with newspapers, tablecloths, curtains, etc.
- This apparatus with Class I construction shall be connected to an AC outlet with a protective grounding connection.
- This apparatus is not disconnected from the mains as long as it is connected to an AC outlet, even if the unit itself has been turned off.
- The rating label appears on the bottom of this apparatus.

## For customers in the USA

	<b>CAUTION</b> <b>RISK OF ELECTRIC SHOCK</b> <b>DO NOT OPEN</b>	
<b>Caution:</b> To prevent electric shock, do not remove the cover. There are no user-serviceable parts inside. Internal adjustments are for qualified professionals only. Refer all servicing to qualified service personnel.		

	The lightning flash with arrowhead symbol, within an equilateral triangle, is intended to alert the user to the presence of uninsulated "dangerous voltage" within the product's enclosure that may be of sufficient magnitude to constitute a risk of shock to persons.
---	--

	The exclamation point symbol within an equilateral triangle is intended to alert the user to the presence of important operating and maintenance (servicing) instructions in the literature accompanying the product.
---	---

## Important Safety Instructions

1. Read these instructions.
2. Keep these instructions.
3. Heed all warnings.
4. Follow all instructions.
5. Do not use this apparatus near water.
6. Clean only with dry cloth.
7. Do not block any ventilation openings. Install in accordance with the manufacturer's instructions.
8. Do not install near any heat sources such as radiators, heat registers, stoves, or other apparatus (including amplifiers) that produce heat.
9. Do not defeat the safety purpose of the polarized or grounding-type plug. A polarized plug has two blades with one wider than the other. A grounding type plug has two blades and a third grounding prong. The wide blade or the third prong are provided for your safety. If the provided plug does not fit into your outlet, consult an electrician for replacement of the obsolete outlet.
10. Protect the power cord from being walked on or pinched particularly at plugs, convenience receptacles, and the point where they exit from the apparatus.
11. Only use attachments/accessories specified by the manufacturer.
12. Use only with a cart, stand, tripod, bracket or table specified by the manufacturer, or sold with the apparatus. When a cart is used, use caution when moving the cart/apparatus combination to avoid injury from tip-over.
13. Unplug this apparatus during lightning storms or when unused for long periods of time.
14. Refer all servicing to qualified service personnel. Servicing is required when the apparatus has been damaged in any way, such as power-supply cord or plug is damaged, liquid has been spilled or objects have fallen into the apparatus, the apparatus has been exposed to rain or moisture, does not operate normally, or has been dropped.



## FCC Notice

### Warning:

This device complies with Part 15 of the FCC Rules. Operation is subject to the condition that this device does not cause harmful interference.

### Caution:

You are cautioned that any changes or modifications not expressly approved in this manual could void your authority to operate this equipment.

**Note:** This equipment has been tested and found to comply with the limits for a Class B digital device, pursuant to part 15 of the FCC Rules. These limits are designed to provide reasonable protection against harmful interference in a residential installation. This equipment generates, uses and can radiate radio frequency energy and, if not installed and used in accordance with the instructions, may cause harmful interference to radio communications. However, there is no guarantee that interference will not occur in a particular installation. If this equipment does cause harmful interference to radio or television reception, which can be determined by turning the equipment off and on, the user is encouraged to try to correct the interference by one or more of the following measures:

- Reorient or relocate the receiving antenna.
- Increase the separation between the equipment and receiver.
- Connect the equipment into an outlet on a circuit different from that to which the receiver is connected.
- Consult the dealer or an experienced radio/TV technician for help.

## Notes on use

- Two transmitters on the same frequency cannot be used simultaneously.
- Please be aware that interference may be generated from the surrounding electromagnetic environment and/or from using multiple units.
- The wireless system may be affected by electromagnetic noise from automobile spark plugs, light dimmers, computers, OA devices, or electrical music instruments. Position the components of the system in a place where it is less likely to be affected.
- Only use this product in combination with devices specified by the manufacturer.
- Insert the plugs of connecting cables securely into their mating connectors.
- Radio waves in the UHF band propagate mainly by line of sight. Configure system so there are no obstructions between the transmitter and receiver.
- Do not use outside the USA. Use abroad may be punished according to the laws of the relevant country.
- Unplug the product when unused for long periods of time.
- Use 120 V AC power source. Refer to "Specifications" for product ratings.

## Using multiple wireless systems

- When using multiple units simultaneously, maintain approximately 1 meter or more between individual transmitters and approximately 10 meters or more between transmitters and receivers.
- When using multiple units, power on transmitters one by one, making sure there is no unwanted noise.

## Maintenance

- When you unplug the power cable, if the plug is dusty or dirty, wipe it off with a soft, dry cloth.
- Do not use anything like benzene or paint thinner to clean the product.
- When storing the system for an extended period, wrap the device in plastic to protect it from dust.

## Part names and functions <front panel>

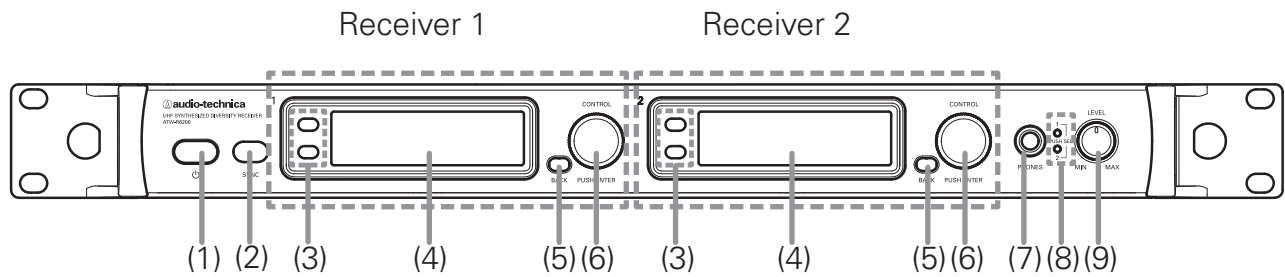

### (1) Power switch

Press the switch to turn the power on.  
The display lights up when the power is turned on.

\* There will be a delay of up to 5 seconds between powering on and audio output from the product.

Press the switch again to turn the power off.

### (2) IR sync window

Use when syncing transmitter to the product.

\*This is shared by receivers 1 and 2.

### (3) Function buttons

Upper button (FN1): Switches the level meter display.  
Lower button (FN2): Minimum hold (only in level meter display mode).

### (4) Display

Displays the product state and setting menus.

### (5) BACK button

Takes the display back one screen when pressed.

### (6) Control dial

Turn to scroll through settings and press to set them.

### (7) Headphone monitor (6.3 mm) output jack

This is the headphone output jack used for monitoring.  
It allows you to monitor receivers 1 and 2.

### (8) Headphone channel indicator

Displays which receiver is being monitored, receiver 1 or 2.

### (9) Headphone volume

Use when adjusting the volume of the headphones for monitoring.

Press and release the knob to switch between receivers 1 and 2.

\*Does not affect receiver audio output level.

## Part names and functions <rear panel>

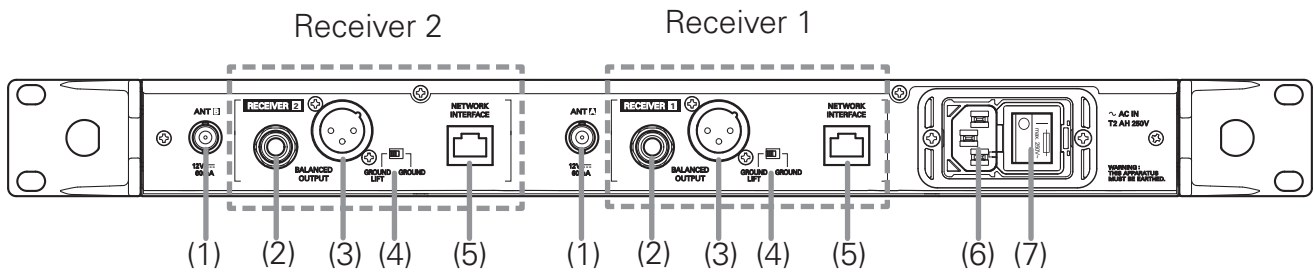

### (1) Antenna input jack

Each of the antenna jacks can supply 12 V DC for use with powered antennas or accessories (sold separately).

### (2) Balanced output jack (6.3 mm (1/4") standard stereo jack)

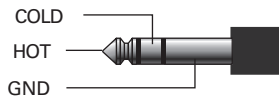

### (3) Balanced output jack (XLR 3-pin male)

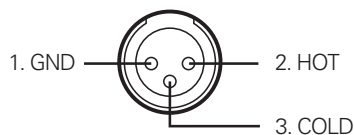

### (4) Ground lift switch

This switch isolates the GND pin of the balanced output from the ground. Normally use in the GROUND position, but if a hum develops due to a ground loop, switch to the "GROUND LIFT" side.

### (5) Network interface

Connecting to a PC via Ethernet cable allows you to monitor and control the system from the PC. For details, contact your local Audio-Technica dealer.

### (6) AC IN terminal

Use the IEC-type connector for 120 V AC 60 Hz power input.

\*This product is only for use in the USA. It may not be used abroad.

### (7) Main power switch

Press the main power switch to turn the power on. Turn the main power switch on before turning the front panel power switch on.

## Part names and functions <display>

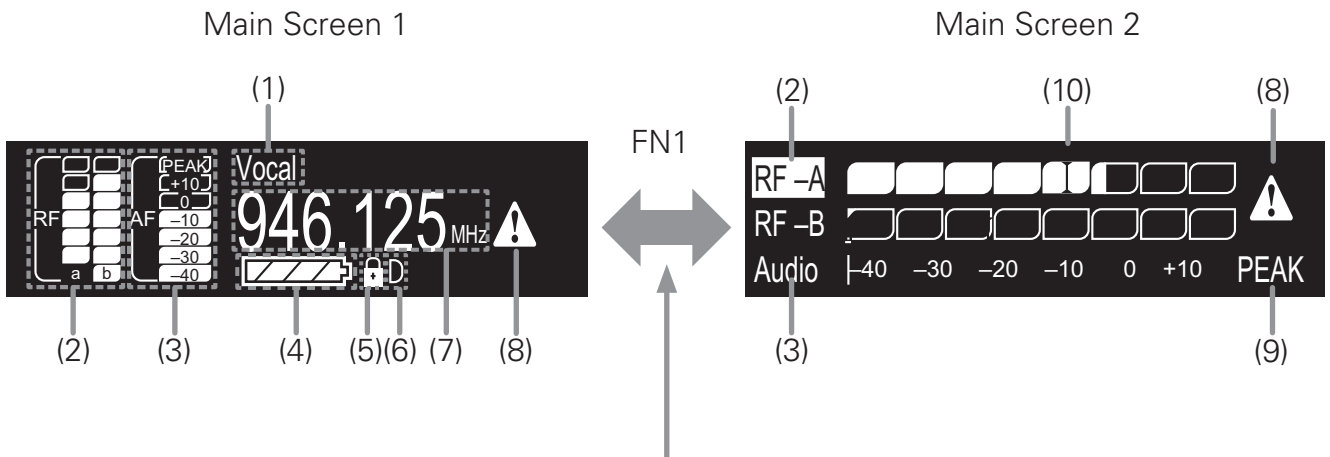

Each time you press the Function button (FN1) on the main screen, it switches between screens.

\*When on any screen other than the main screen, pressing the Function button (FN1) switches it back to main screen 1.

### (1) NAME

Displays the specified name.

### (2) RF level indicator

Displays the reception states of antennas A & B, respectively.

### (3) AF level indicator

Displays the received audio signal level.

### (4) Battery level

Shows the battery level of the transmitter.



: 75% or more battery power remaining.



: 50 to 75% battery power remaining.



: 25 to 50% battery power remaining.



: 25% or less battery power remaining.



: Charge/replace the batteries.

\*Use as a general guide for determining how much battery power has been consumed.

\*If there is no remaining battery power, replace the transmitter's batteries. If rechargeable batteries are being used, recharge them.

### (5) Key lock and network remote



: Key lock is ON



: Network remote state

### (6) DHCP server operation indicator

Displayed when the DHCP server operation setting is ON.

### (7) Frequency

Displays the set frequency.

### (8) Mute indicator

An exclamation point icon is displayed when muted.

### (9) Peak indicator

Displayed if the AF level exceeds +18 dBV.

### (10) Marker (when the minimum hold function is on)

The RF level is held at a minimum value.

## Minimum hold function

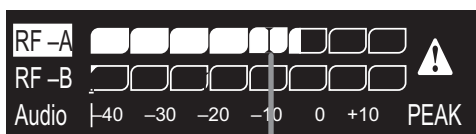
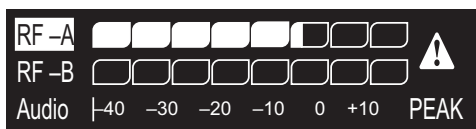

Marker

(1) When on the main screen, pressing the function button (FN1) switches the display to main screen 2.

(2) If you press and hold the function button (FN2), the minimum hold function turns on and its marker is displayed.

- The marker indicates the lowest-level RF signal received from the transmitter.
- The marker does not move even if the input RF level is higher than the marker position.
- If the RF level input is lower than the marker position, the marker moves in tandem with the RF level.
- To reset the marker position, press the Function button (FN2).

## System operation

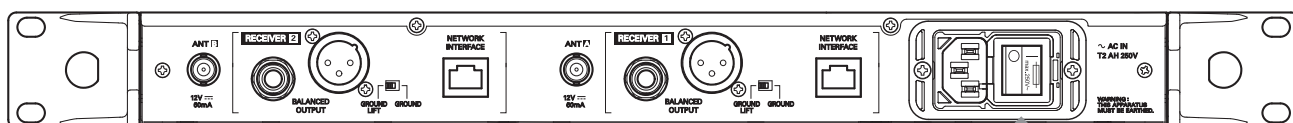

Rear Panel

(1) Main power switch

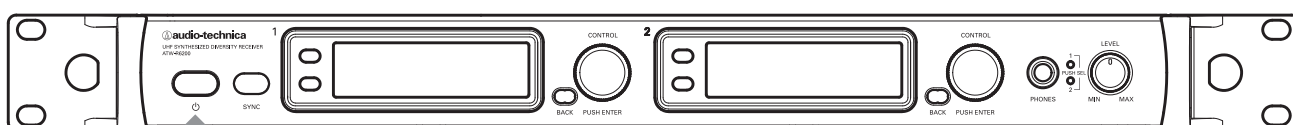

Front Panel

(2) Power switch

- (1) Turn the main power switch on the rear panel [ON].
- (2) Turn the power switch on the front panel [ON].
  - The display lights and the frequency is displayed.
- (3) Set the operating frequency (see p. 10).
- (4) Turn the transmitter's power on and sync with receiver (see p. 18).
  - The RF level indicator lights up.
- (5) Check the RF level indicator.
  - Check that antenna A or B lights up.
- (6) Speak into the mic.
  - Make sure the AF level indicator lights up.



# Settings

## Main menu

The various settings of this product can be made from the main menu.



(1) On the main screen, press or turn the control dial to display the main menu.



(2) Turn the control dial to select the item you wish to set.

(3) Pressing the control dial opens the settings menu of the selected item.

- Press the BACK button to go back one screen.
- To cancel part way through making a setting, press the BACK button.
- While in the setting mode, the display will return to the main screen if 30 seconds pass without a button or the control dial being used.

## Items configurable from the main menu

Frequency Management	Sets the operating frequency and corresponding name.
Squelch	Sets the squelch level.
Audio Settings	Sets the audio output level, and the line/mic levels.
System Settings	Configures the following functions: <ul style="list-style-type: none"> <li>• Key lock</li> <li>• Antenna power</li> <li>• IR sync</li> <li>• Screen saver</li> <li>• Factory-defined defaults</li> </ul>
TX SYNC	Syncs transmitter with the product.
Network	Configures network settings.

## Setting the operating frequency

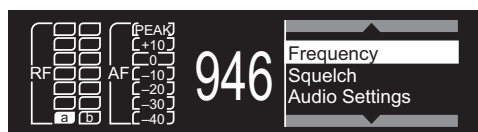

(1) From the main menu, turn the control dial, select [Frequency] and then press the control dial.

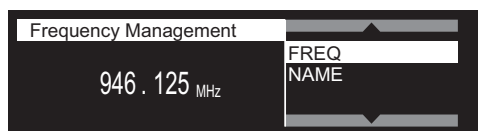

(2) Select [FREQ] and press the control dial.

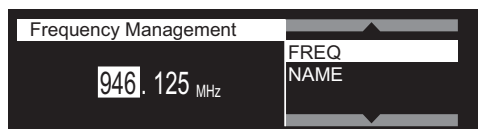

(3) Turn the control dial and set the first 3 digits. When finished setting them, press the control dial.

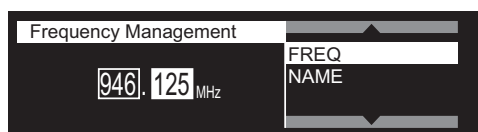

(4) Turn the control dial and set the last 3 digits. When finished setting them, press the control dial.

- The setting is complete.

## Setting the name

The following characters can be entered:

- Alphabetical characters (upper and lower case)
- Symbols (+, -, period)
- Numbers
- Spaces



(1) From the main menu, turn the control dial, select [Frequency] and then press the control dial.



(2) Select [NAME] and press the control dial.

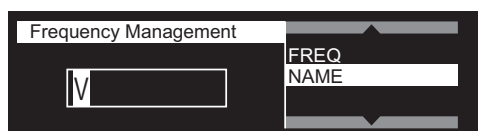

(3) Turn the control dial to display the character you wish to set and then press the control dial.

- The character is input and the cursor moves to the right.



(4) Enter all the desired characters in the same way as in step (3) and then press the control dial.

- The NAME is saved.

**NOTE:** A total of 10 characters must be entered. If less than 10 characters are desired, select SPACE and press the control dial until the cursor moves to the 10th character position.

## Correcting characters

There are two ways to correct text that has been entered.

- If you wish to delete text

Turn the control dial and select [BS]. When you press the control dial, the cursor moves one space to the left, backspacing over the last character entered.

- To move to the character you wish to correct

Press the BACK button and the cursor moves back one place. Move the cursor back to the character you wish to change. Turn the control dial to display the character you wish to set and then press the control dial.

## Setting the squelch level

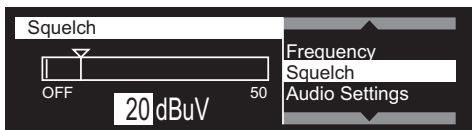

- (1) From the main menu, turn the control dial, select [Squelch] and then press the control dial.

- (2) Turn the control dial and select the value you wish to set.
  - The meter indicates the RF level.
  - You can set it from OFF up to the maximum 50dB $\mu$ V.
  - The default setting is 20dB $\mu$ V.

- (3) Press the control dial.
  - The setting is complete.

## Setting the audio output level

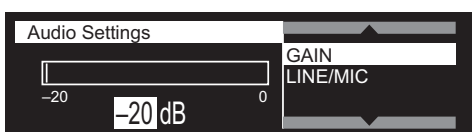
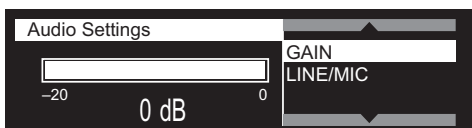

- (1) From the main menu, turn the control dial, select [Audio Settings] and then press the control dial.

- (2) Select [GAIN] and press the control dial.

- (3) Turn the control dial and set the audio output level.
  - The level changes 2dB +/- each time you turn the control dial.
  - It can be set from -20 to 0dB.

- (4) Press the control dial.
  - The setting is complete.

## Setting the line and mic levels

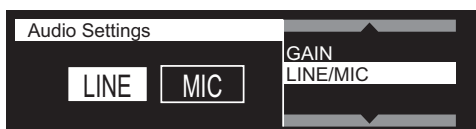

(1) From the main menu, turn the control dial, select [Audio Settings] and then press the control dial.

(2) Select [LINE/MIC] and press the control dial.

(3) Turn the control dial and select either [LINE] or [MIC].

(4) Press the control dial.

- The setting is complete.

## Setting the system-related functions

### Setting the key lock

Set this function to prevent the product settings from being changed.

\*The default setting is [OFF].

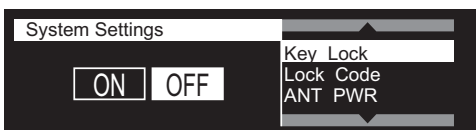
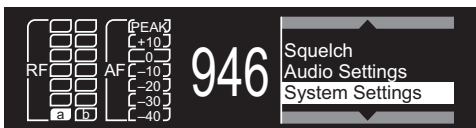

(1) From the main menu, turn the control dial, select [System Settings] and then press the control dial.

(2) Select [Key Lock] and press the control dial.

(3) Turn the control dial, select [ON] or [OFF] and then press the control dial.

- The setting is complete.

## Setting the lock code

The lock code is a 4-digit number used with the key lock. (Can be set from "0000" to "9999".)

When the key lock function is activated, the lock code is required to access the menu from the main screen.

\*The default setting is "0000".



(1) From the main menu, turn the control dial, select [System Settings] and then press the control dial.



(2) Select [Lock Code] and press the control dial.



(3) Turn the dial to select a number and then press the control dial.

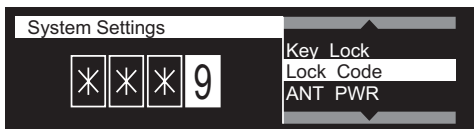

(4) Repeat the operation until all 4 numbers are entered and then press the control dial.

- The setting is complete.

## Setting the antenna power

This turns power on/off to the antenna input terminals.

\*The default setting is [OFF].

\*This can only be set from receiver 1.

\*If set to [ON], power is supplied to both antennas A and B.

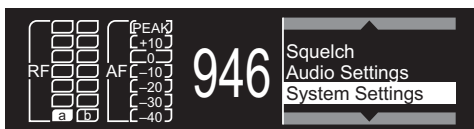

(1) From the main menu, turn the control dial, select [System Settings] and then press the control dial.



(2) Select [ANT PWR] and press the control dial.

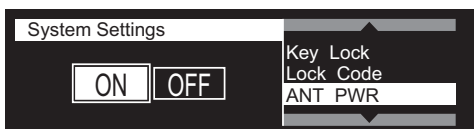

(3) Turn the control dial, select [ON] or [OFF] and then press the control dial.

- The setting is complete.

## Setting transmitters via IR sync

This function allows you to make transmitter settings on the product and then automatically configure the transmitter via IR sync.



(1) From the main menu, turn the control dial, select [System Settings] and then press the control dial.

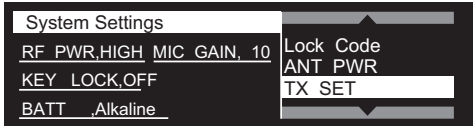

(2) Select [TX SET] and press the control dial.



(3) To set the [RF PWR], turn the control dial, select [HIGH], [MID] or [LOW] and then press the control dial.

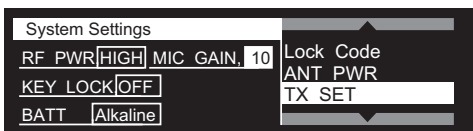

(4) To set the [MIC GAIN], turn the control dial, select the gain and then press the control dial.

- The gain can be set in steps of 2dB.
- The maximum setting is 20dB.



(5) To set the [KEY LOCK] (transmitter key lock), turn the control dial, select [ON] or [OFF] and then press the control dial.



(6) To set the [BATT] (type of battery used in the transmitter), turn the control dial, select [Alkaline] or [Ni-MH] and then press the control dial.

Alkaline	Select when using alkaline batteries.
Ni-MH	Select when using nickel-metal hydride batteries.

- The setting is complete.

**NOTE:** For how to sync a transmitter with the receiver, refer to "Setting up transmitter via IR sync" (p.18).

## Screen saver settings

This sets the length of time before the display turns off from inactivity.

\*The default setting is set to "OFF" and the screen does not turn off.

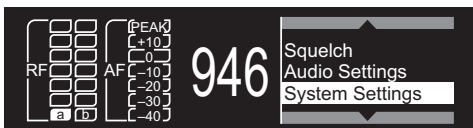

(1) From the main menu, turn the control dial, select [System Settings] and then press the control dial.

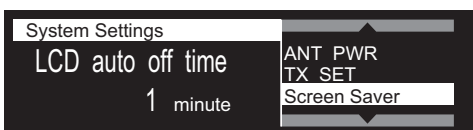

(2) Select [Screen Saver] and press the control dial.



(3) Turn the control dial, select the desired amount of time and then press the control dial.

- The setting is complete.
- If you select [OFF], the display will not turn off.
- The time can be set from 1 to 99 minutes.

## Resetting factory defaults

This returns the settings to their factory defaults.



- (1) From the main menu, turn the control dial, select [System Settings] and then press the control dial.



- (2) Select [RESET] and press the control dial.



- (3) Select [YES] and press the control dial.
  - Reset starts. After the reset is complete, the product powers off and on.

## Checking the product information

This function displays product information.

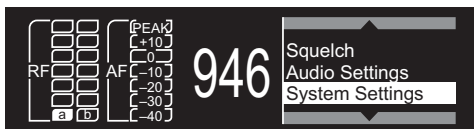

- (1) From the main menu, turn the control dial, select [System Settings] and then press the control dial.

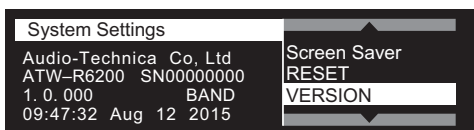

- (2) Select [VERSION].
  - Product information is displayed.

- Information you can check:

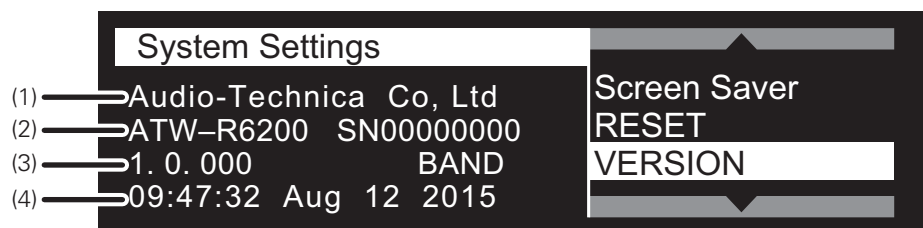

- (1) Company name
- (2) Product model and serial number
- (3) Firmware version and frequency band name
- (4) Date/time firmware created

## Setting up the network

Connecting to a PC via Ethernet cable allows you to monitor and control the system from the PC.

The settings made here are not reflected until the product is restarted. After you change settings, a screen opens to inform you that you have to restart.

### Obtaining an IP address

This sets how the IP address is selected.



(1) From the main menu, turn the control dial, select [Network] and then press the control dial.

(2) Select [IP Select] and press the control dial.

(3) Select the desired setting and press the control dial.

AutoIP	This sets the system to automatically assign an IP address.
STATIC	This sets the system to use a fixed IP address.

- The setting is complete. Restart the product after completing all the network settings.

### Setting the IP address

This configures the IP address.

\*This can only be configured when [IP Select] is set to [STATIC].

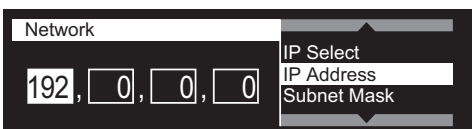
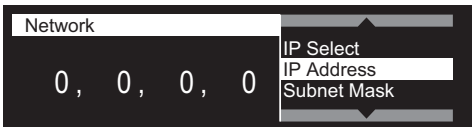

(1) From the main menu, turn the control dial, select [Network] and then press the control dial.

(2) Select [IP Address] and press the control dial.

(3) Turn the dial and select the number you wish to set and press the control dial.

(4) Repeat the operation until all the numbers are entered and then press the control dial.

- The setting is complete. Restart the product after completing all the network settings.



## Setting the subnet mask

This configures the subnet mask.

\*This can only be configured when [IP Select] is set to [STATIC].

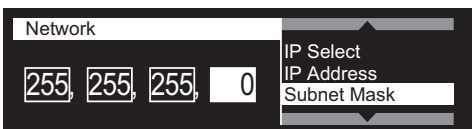
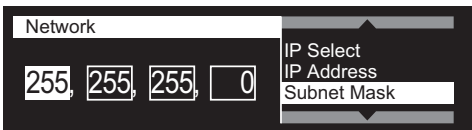
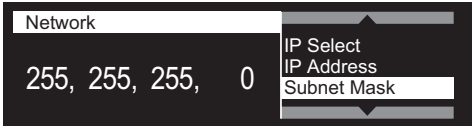

(1) From the main menu, turn the control dial, select [Network] and then press the control dial.

(2) Select [Subnet Mask] and press the control dial.

(3) Turn the dial and select the number you wish to set and press the control dial.

(4) Repeat the operation until all the numbers are entered and then press the control dial.

- The setting is complete. Restart the product after completing all network settings.

## Displaying the MAC address

This allows you to check the MAC address.

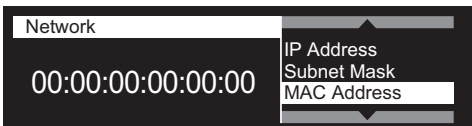

(1) From the main menu, turn the control dial, select [Network] and then press the control dial.

(2) Select [MAC Address].

- The MAC address is displayed.

## Changing the DHCP server setting

This sets whether or not to use a DHCP server.

\*If you wish to use a DHCP server, you must set [IP Select] to [STATIC].

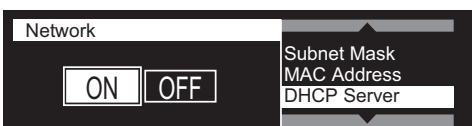
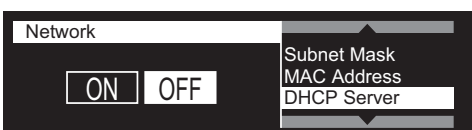

(1) From the Main menu, turn the control dial, select [Network] and then press the control dial.

(2) Select [DHCP Server] and press the control dial.

(3) Turn the dial and select either [ON] or [OFF] and press the control dial.

- The setting is complete. Restart the product after completing all network settings.

## Setting up transmitter via IR sync

This function allows you to send the settings configured on the product to the transmitter via IR sync.

\*First refer to the section "Setting transmitters via IR sync" (p. 14) and then make the settings.

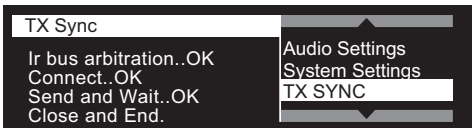
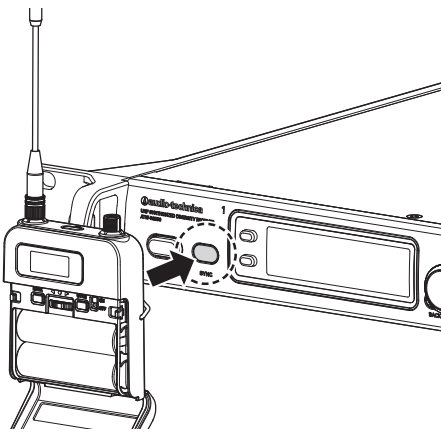
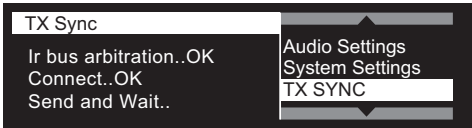

(1) From the main menu, turn the control dial, select [TX SYNC] and then press the control dial.

(2) A standby screen is displayed.

- Press the BACK button to return to the main menu.
- If 60 seconds pass without a button/dial being used, the display will return to the main menu.

(3) While in standby mode, position the IR sync windows of the product and transmitter so they face each other.

(4) Press the SYNC button on the transmitter.

- Wait several seconds until communication is established.

(5) When the sync is complete, the "completed" screen is displayed.

- The settings made on the product are automatically sent to the transmitter.
- After sync is complete, the display returns automatically to the main screen.
- If an error occurs in the syncing process, an error screen opens and then the display returns to the main menu. Check the alignment of the IR sync windows of the receiver and transmitter and then sync again.
- To cancel the syncing process, press the BACK button. Display returns to the main menu.

## Using the key lock function

The key lock function prevents entry to the main menu to avoid any unwanted changes to the system's settings.

When the key lock function is set to [ON], the main screen is displayed, but a lock code is required in order to access the main menu.

### Setting up the key lock function

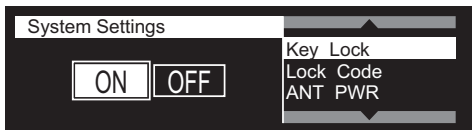

(1). Set up a lock code.

- For details, refer to "Setting the lock code" on p. 13.
- Do not forget the 4-digit code you set up.

(2) Set the key lock function to [ON].

- For details, refer to "Setting the key lock" section on p. 12.

(3) The key lock function is enabled once you press the BACK button and return to the main screen.

### Cancelling the key lock function

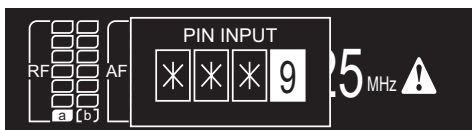
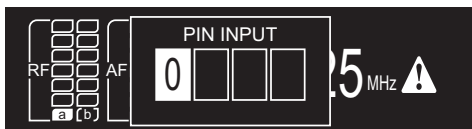
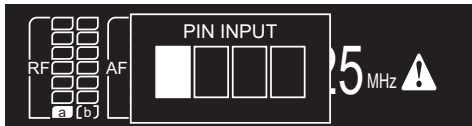

(1) When the key lock is enabled, the PIN INPUT screen is displayed when you press or turn the control dial on the main screen.

(2) To release the lock, enter the 4-digit lock code. Turn the control dial to select a number and then press the control dial. Once you enter a number, the cursor moves to the right. Repeat the steps to enter the 4-digit lock code.

(3) After the entire 4-digit code is entered, press the control button. If the correct lock code was entered, the main menu will display.

(4) The key lock function can be released by turning the key lock setting [OFF].

## Making connections (basic connections)

This example is of connections made when using one ATW-R6200 S.

When connecting more than one ATW-R6200 S via a distributor (sold separately), refer to the distributor's user manual.

### Connection example

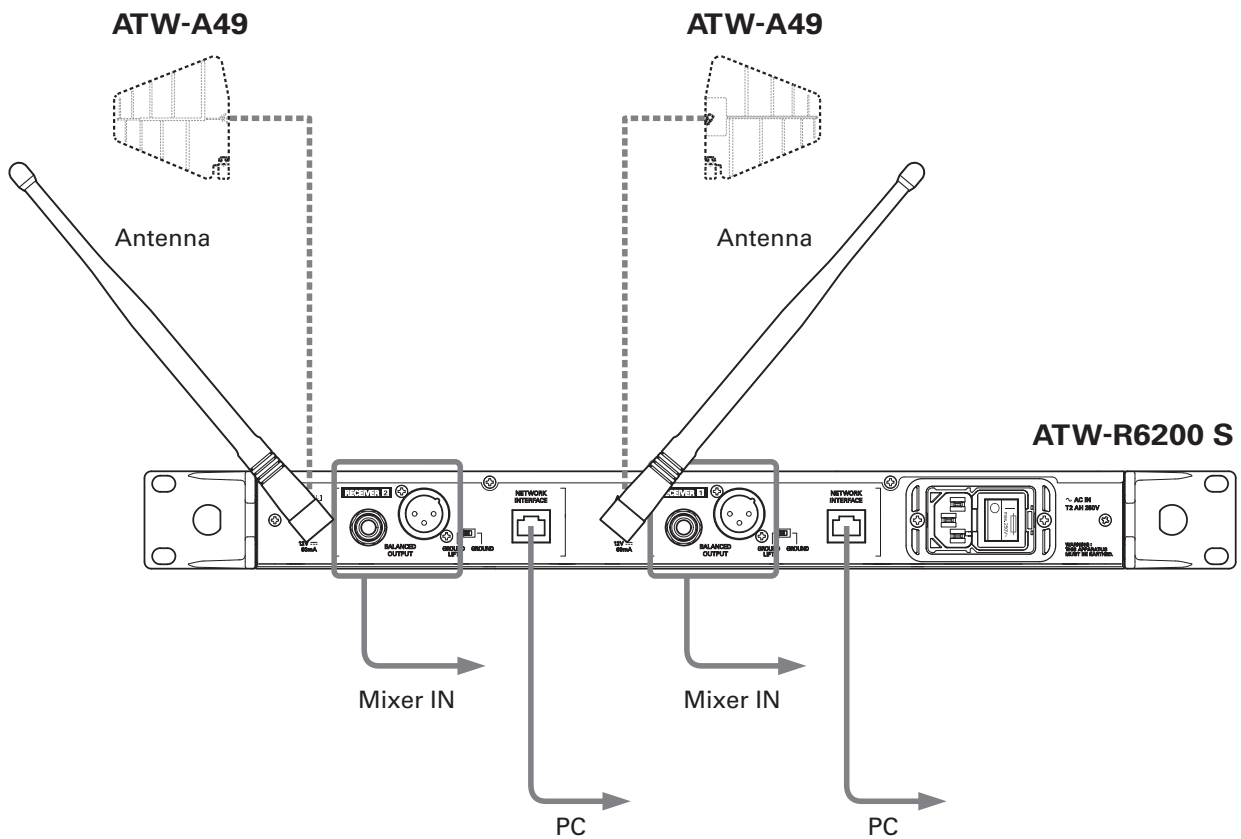

**NOTE:** The example connection shown above uses the supplied antennas. When using the product in a large space or on a stage, connect it to UHF wideband LPDA antennas ATW-A49 (sold separately), as shown by the dotted lines.

## Example using an external antenna (sold separately)

### Caution on antenna location

The distance between antennas A and B should be at least 30 cm and less than 30 m.  
Otherwise diversity reception can be lost.

### When using 1 set (ATW-A49)

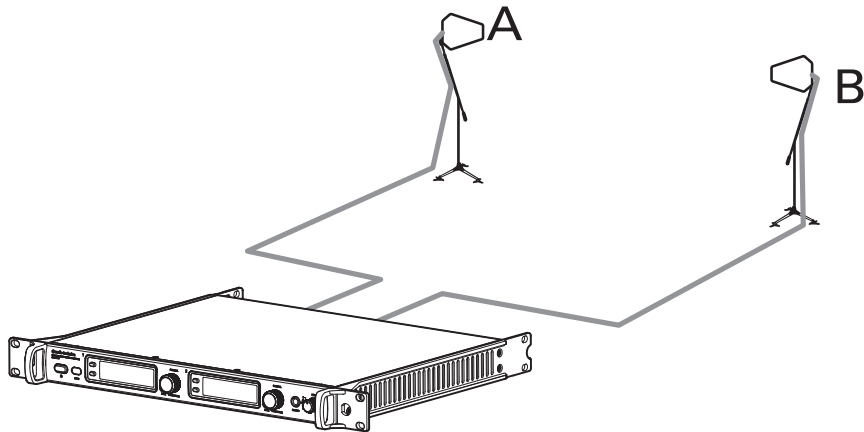

## Achieving stable reception

Low RF signal may result if there are obstructions between receiver antennas and transmitter(s).  
In such a case, reposition the antennas to get better reception.

## Front antenna connections

- To connect the antennas to the front of the product, attach all parts as shown below.

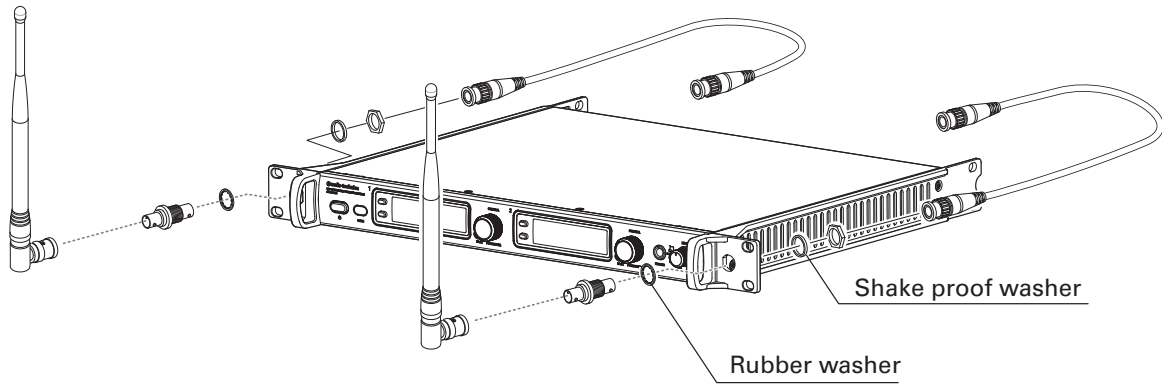

## Rack mounting receivers

- Screws for rack mounting the product are not included.
- Consider ventilation when rack mounting to avoid heat building up in the rack.

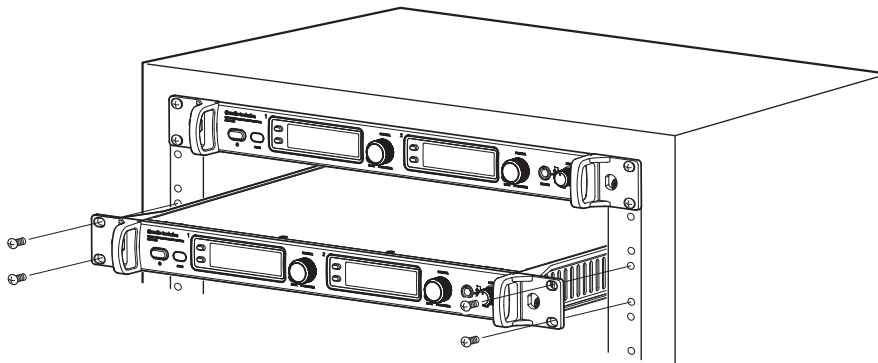

## Specifications

Receiving system	: True diversity
Operating frequency	: 946.125 to 949.875 MHz
Simultaneous channels	: Total of 31 channels (125kHz intervals)
RF sensitivity	: 20 dB $\mu$ V (at 60dB S/N ratio)
Total harmonic distortion	: <1% (63 dB $\mu$ V input, 1 kHz, frequency deviation $\pm$ 10 kHz)
SN ratio	: 110 dB or more
Audio output level	: XLR balanced $\geq$ +18 dBV (LINE), $\geq$ +4 dBV (MIC) (frequency deviation $\pm$ 15 kHz) $\Phi$ 6.3 balanced $\geq$ +18 dBV (LINE), $\geq$ +4 dBV (MIC) (frequency deviation $\pm$ 15 kHz)
Antenna input jack	: BNC type (50 ohm) 12 V DC OUT (max 60 mA x 2)
Audio output terminal	: XLR 3-pin male (balanced) 6.3 mm (1/4") standard stereo jack (balanced)
Headphone OUTPUT jack	: 6.3 mm (1/4") standard stereo jack; max power output: 100 mW + 100 mW into 32 ohms
Power	: 120 V AC 60 Hz
Operating temperature range	: 5 $^{\circ}$ C to 45 $^{\circ}$ C (41 $^{\circ}$ F to 113 $^{\circ}$ F)
Power consumption	: 25 W
External dimensions (excluding protrusions)	: 482 mm (18.97") x 43 mm (1.69") x 361 mm (14.21") (W x H x D)
Weight	: 4.7 kg (10.4 lbs)

- Accessories 1/2  $\lambda$  whip antenna x 2, Power cable, Legs x 4 (4 mounting screws), Front mount antenna cables and connectors
- This product is for use in the USA only.
- Specifications are subject to change without prior notice.

## Dimensions

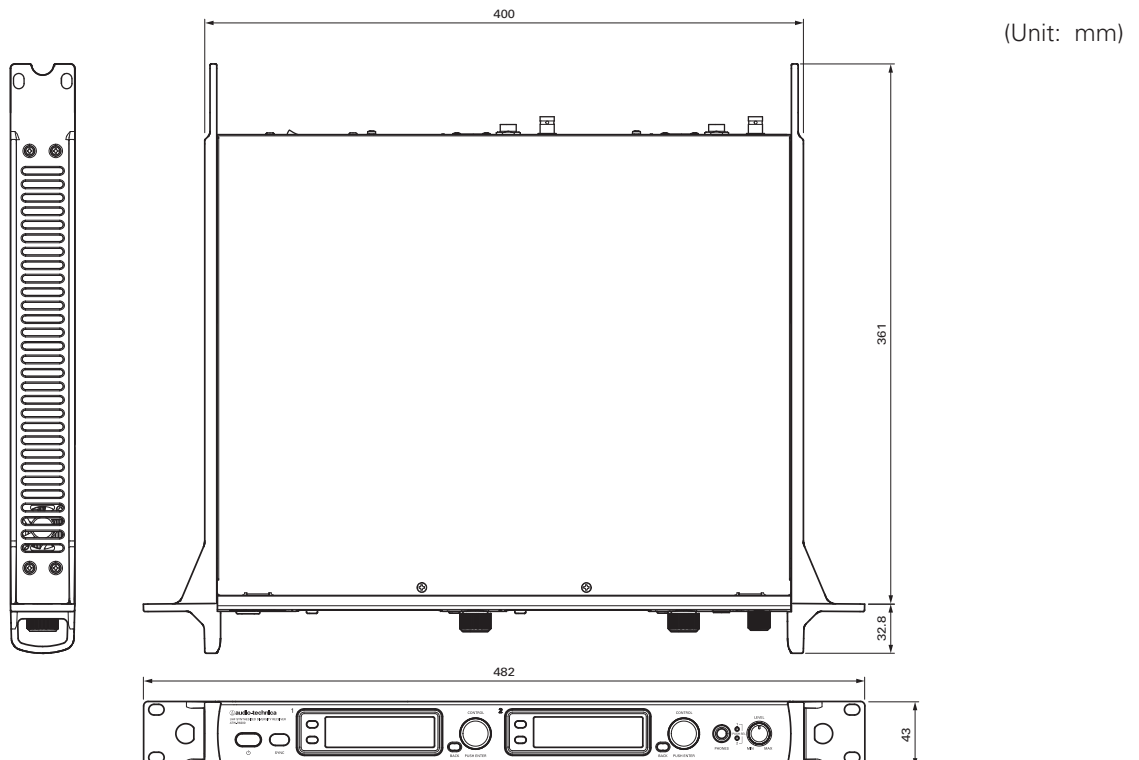



Audio-Technica Corporation  
©2017 Audio-Technica Corporation

232305390-01-02 ver.1 2016.03.31  
ver.2 2017.02.01