

Engineered Sound®

AT935QMRx/H
Hypercardioid

Description

The AT935QMRx/H is a wide-range condenser microphone with a hypercardioid polar pattern. It is designed for quality sound reinforcement, professional recording, television, and other demanding sound pickup applications. The small-diameter gooseneck design permits highly flexible positioning while maintaining a smooth, well-contoured appearance.

The microphone features an XLRM-type connector insert at its base, allowing it to be plugged directly into an XLRF-type panel jack or microphone cable. The integral power module can be powered from any external 9V to 52V DC phantom power supply. A recessed switch in the power module permits choice of flat response or low-frequency roll-off to help control undesired ambient noise.

Four additional interchangeable elements are available to permit selection of angle of acceptance from 90° to 360°.

Audio-Technica design engineers have utilized the newest low-mass diaphragm technology in the quest for superior performance. The permanent charge is now on the fixed back plate, rather than the moving element. With A-T fixed-charge "back plate" construction, a gold-vaporized diaphragm just 2 microns thick (about .000079") can be used. This considerably reduces moving mass, thus improving frequency response and transient response while reducing distortion.

The microphone is enclosed in a rugged housing with a low-reflectance black finish.

Installation and Operation

Output is low impedance balanced. The output connector mates with XLRF-type connectors. The balanced signal appears across Pins 2 and 3, while the ground (shield) connection is Pin 1. Output is phased so that positive acoustic pressure produces positive voltage at Pin 2, in accordance with industry convention.

The microphone can be secured to a podium or desktop with the included locking ring/isolator. Rubber-insulated feet attenuate noise, shock and vibration transmitted through the mounting surface. A nylon compression bushing utilizes two set screws to hold the microphone securely in place. A template is provided on the back of this sheet to aid in installation of the locking ring/isolator.

The provided foam windscreens simply slips over the head of the microphone, effectively reducing wind noise or "popping" when used extra close.

The small-diameter gooseneck is easy to manipulate for proper positioning. Heavily lubricated, it operates smoothly and quietly. Should the unit become noisy with prolonged use, apply a light machine oil directly on the gooseneck area affected.

While a modern condenser microphone is not unduly sensitive to the environment, temperature extremes can be harmful. Exposure to high temperature can result in gradual and permanent reduction of the output level. Avoid leaving the microphone in the open sun or in areas where temperatures exceed 110° F (43° C) for long periods of time. Extremely high humidity should also be avoided.

Architects and Engineers Specifications

The microphone shall be a fixed-charge condenser with a hypercardioid polar pattern and a frequency response of 40 Hz to 20,000 Hz. It shall be capable of accepting optional interchangeable elements for additional polar patterns. It shall operate from an external 9V to 52V DC phantom power source. Nominal open-circuit output voltage shall be 7.0 mV at 1 kHz, 1 Pascal. Output shall be low impedance balanced (200 ohms).

The microphone shall have a self-contained power module with an XLRM-type connector insert at the base for direct connection to a mating XLRF-type panel jack or cable connector. The power module shall include a switch for low-frequency roll-off. A locking ring/isolator shall be supplied.

The microphone shall be a small-diameter gooseneck design, with an overall length of 7.87" (200.0 mm). Head diameter shall be 0.48" (12.2 mm). The microphone weight shall be 2.5 oz (70 grams). Finish shall be low-reflectance black.

The Audio-Technica AT935QMRx/H is specified.

Frequency Response (Typical)

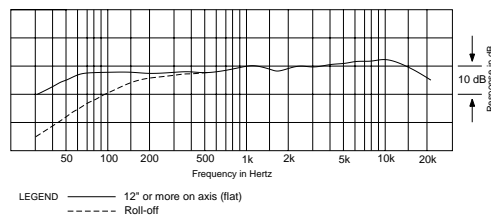

Miniature
Condenser
Gooseneck
Quick-mount
Microphone



audio-technica®

AT935QMRx/H

AT935QMRx/H Specifications†

Element	Fixed-charge back plate permanently polarized condenser
Polar Pattern	Hypercardioid
Frequency Response	40-20,000 Hz
Low-frequency Roll-off	150 Hz, 6 dB/octave
Open Circuit Sensitivity	-43 dB (7.0 mV) re 1V at 1 Pa*
Impedance	200 ohms
Maximum Input Sound Level	138 dB SPL, 1 kHz at 1% T.H.D.
Dynamic Range (Typical)	111 dB, 1 kHz at Max SPL
Signal-to-noise Ratio†	67 dB, 1 kHz at 1 Pa*
Switch	Flat response, low-roll-off (recessed)
Phantom Power Requirements	9-52V DC, 2 mA typical
Weight	2.5 oz (70 grams)
Dimensions	7.87" (200.0 mm) long, 0.48" (12.2 mm) head diameter, 0.83" (21.0 mm) base diameter
Output Connector (Power Module)	Integral 3-pin XLRM-type
Accessories Furnished	AT8102 two-stage foam windscreen; AT8616x locking ring/isolator; element adapter (for C/H/O/SC elements)
Optional Interchangeable Elements	AT853C-ELE cardioid (120°) AT853ML-ELE MicroLine® (90°) AT853O-ELE omnidirectional (360°) AT853SC-ELE subcardioid (170°)

† In the interest of standards development, A.T.U.S. offers full details on its test methods to other industry professionals on request.

* 1 Pascal = 10 dynes/cm² = 10 microbars = 94 dB SPL

† Typical, A-weighted, using Audio Precision System One.

Mounting Template (Actual Size)

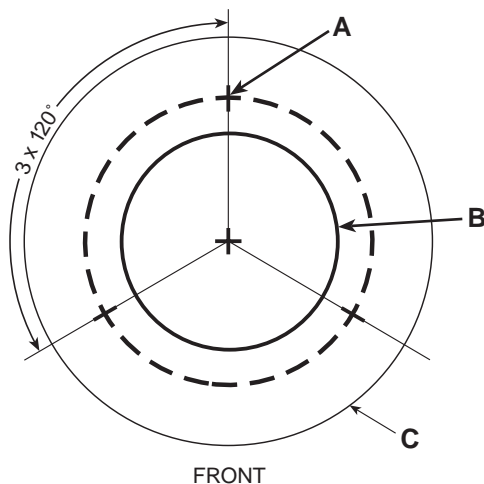

- A. Drill 1/16" (1.5 mm) pilot holes
3 places on 1/2" (38 mm) circle
- B. 1 1/8" (28.6 mm) thru-hole
for cable clearance
- C. Outside edge of flange,
2.13" (54 mm) diameter

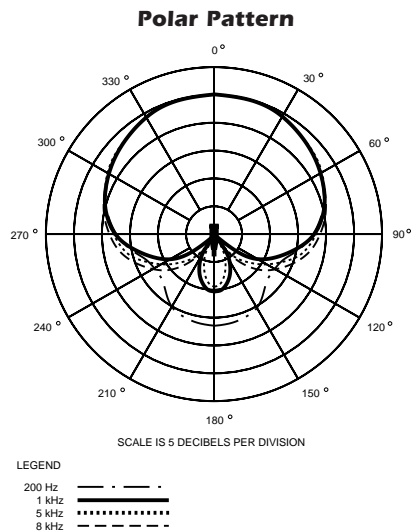

Dimensions

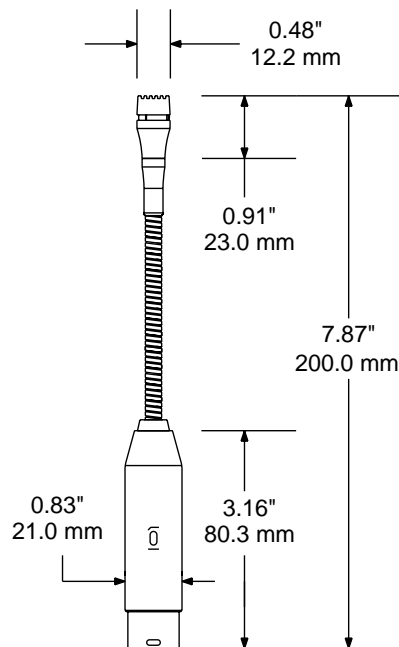

One-Year Limited Warranty

Audio-Technica microphones and accessories purchased in the U.S.A. are warranted for one year from date of purchase by Audio-Technica U.S., Inc. (A.T.U.S.) to be free of defects in materials and workmanship. In event of such defect, product will be repaired promptly without charge or, at our option, replaced with a new product of equal or superior value if delivered to A.T.U.S. or an Authorized Service Center, prepaid, together with the sales slip or other proof of purchase date. **Prior approval from A.T.U.S. is required for return.** This warranty excludes defects due to normal wear, abuse, shipping damage, or failure to use product in accordance with instructions. This warranty is void in the event of unauthorized repair or modification.

For return approval and shipping information, contact the Service Department, Audio-Technica U.S., Inc., 1221 Commerce Drive, Stow, Ohio 44224.

Except to the extent precluded by applicable state law, **A.T.U.S. will have no liability for any consequential, incidental, or special damages; any warranty of merchantability or fitness for particular purpose expires when this warranty expires.**

This warranty gives you specific legal rights, and you may have other rights which vary from state to state.

Outside the U.S.A., please contact your local dealer for warranty details.